

REV
SH
1443AT
DWG NO

REVISIONS			
REV	DESCRIPTION	DATE	APPROVED

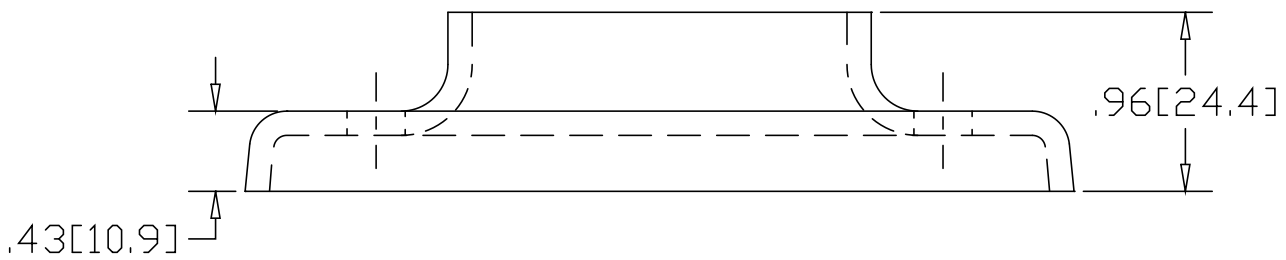
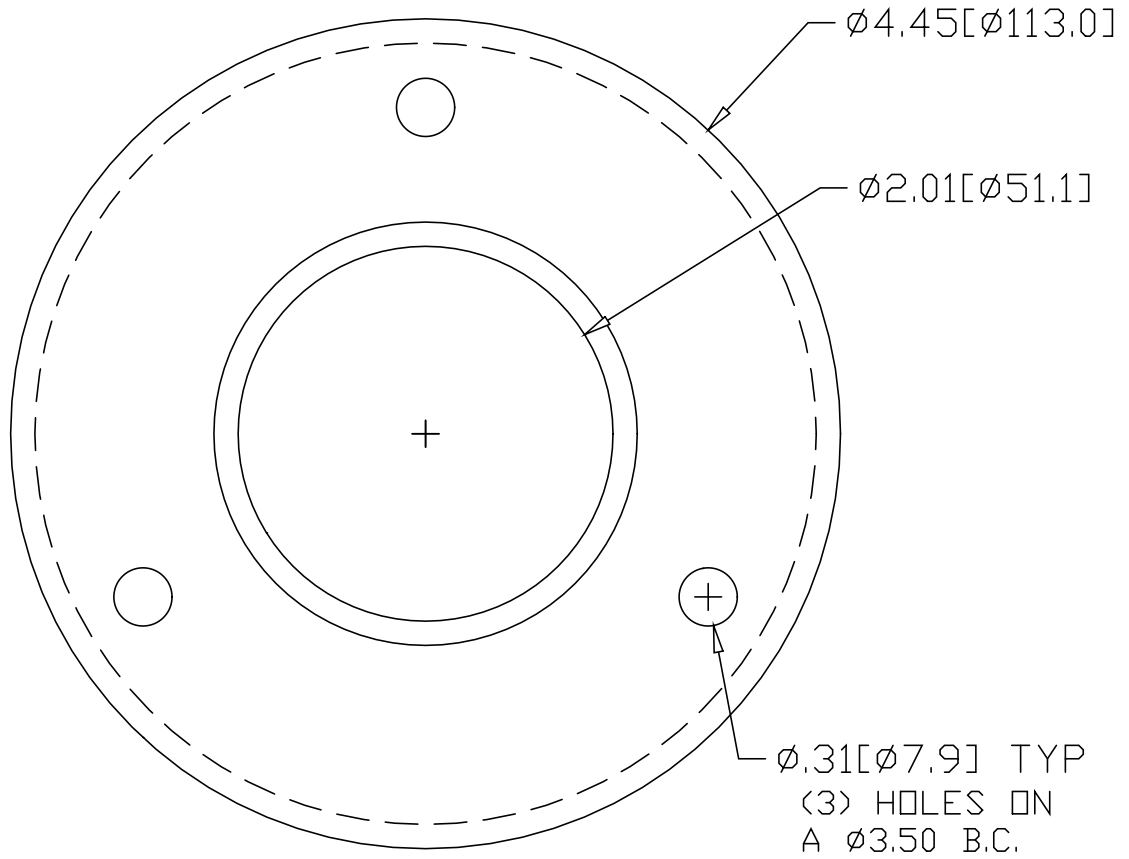

INCHES [MILLIMETERS]

*USE WITH ANCHOR PLATE
 #B1440 IN STEEL
 #PLB1440 ZINC PLATED STEEL
 #B1540 IN STAINLESS

ALTERNATE MATERIAL	PART NUMBER
.125 (3003) ALUMINUM ASTM B209	1483AT
10 GA. (304) STAINLESS STEEL ASTM A240	1543AT

PART NAME 2.00" OD TUBE HEAVY BASE FLANGE W/(3) HOLES			
MATERIAL 10 GA. HRP&D STEEL ASTM A569			
DATE 9/13/94		R & B WAGNER, INC.	
DRAWN BY RJF			
FINISH MILL	SIZE A	WEIGHT .64 LBS	PART NUMBER 1443AT
			REV