

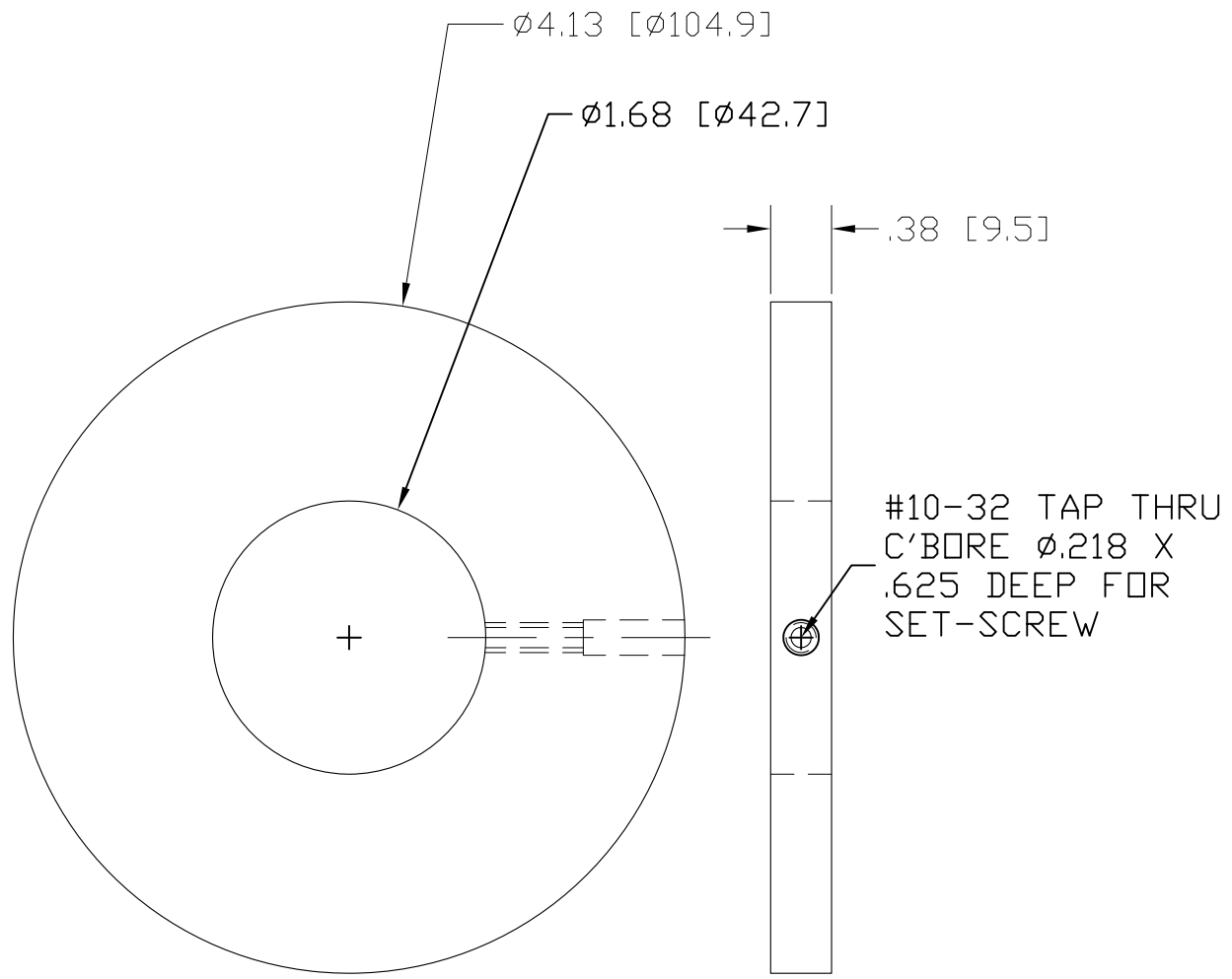

REV
SH
8063
DWG NO

| REVISIONS | | | |
|-----------|-------------|------|----------|
| REV | DESCRIPTION | DATE | APPROVED |



INCHES [MILLIMETERS]

| | | | |
|---|---|----------------|------------------|
| PART NAME 1-1/4" PIPE SIZE ALUMINUM COVER PLATE W/SET-SCREW | | | |
| MATERIAL .375 (6063) ALUMINUM PLATE | | | |
| DATE 9/23/03 |  THE WAGNER COMPANIES R & B WAGNER, INC. AND J. G. BRAUN CO. | | |
| DRAWN BY RJF | | | |
| FINISH MILL | SIZE A | WEIGHT .40 LBS | PART NUMBER 8063 |
| | | | REV |