

REV
SH
DWG NO 3226D

REVISIONS			
REV	DESCRIPTION	DATE	APPROVED

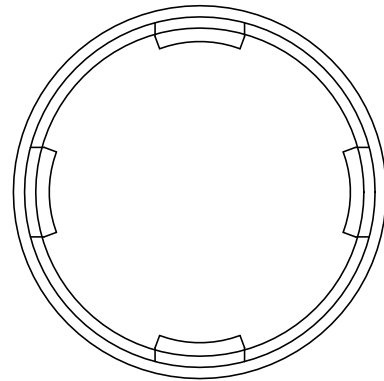
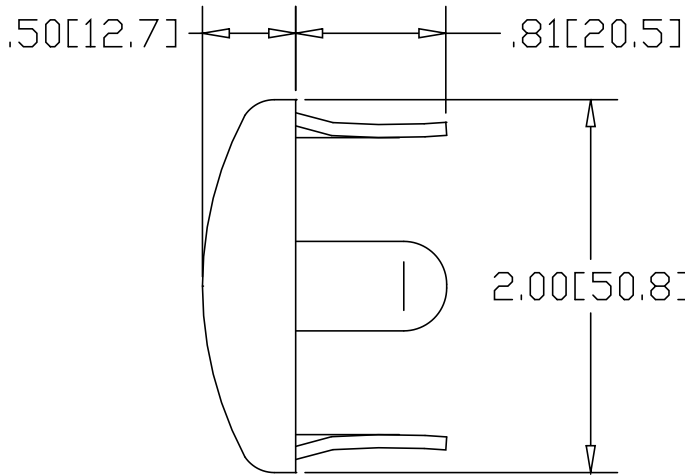
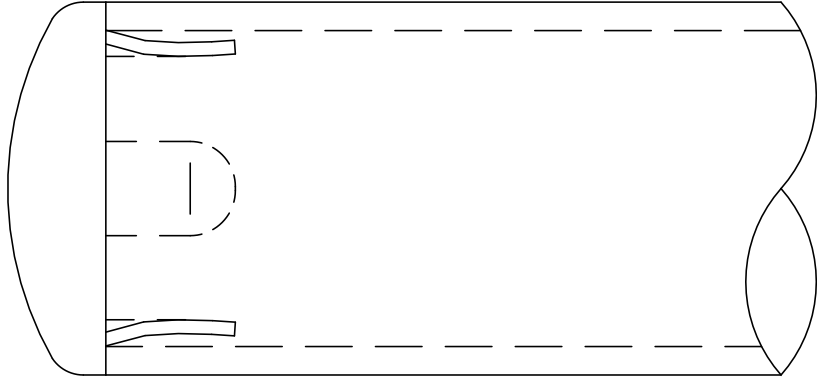
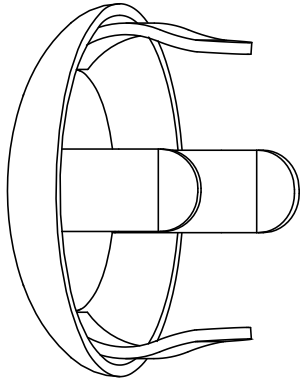

INCHES [MILLIMETERS]

ALTERNATE MATERIAL	PART NUMBER
.063 (3003) ALUMINUM ASTM B-209	3246D
16 GA. (304) STAINLESS STEEL ASTM A240	3266D

NOTE: ALUMINUM AND STAINLESS STEEL CAPS HAVE #4 SATIN FINISH.

PART NAME		2.00" OD X .120W TYPE "H" OVAL DRIVE-ON END CAP					
MATERIAL		16 GA. HRP&D STEEL ASTM A-569					
DATE	7/10/96	 THE WAGNER COMPANIES R & B WAGNER, INC. AND J. G. BRAUN CO.					
DRAWN BY	RJF						
FINISH	MILL SEE NOTE						
SIZE	A	WEIGHT	.14 LBS	PART NUMBER	3226D	REV	