

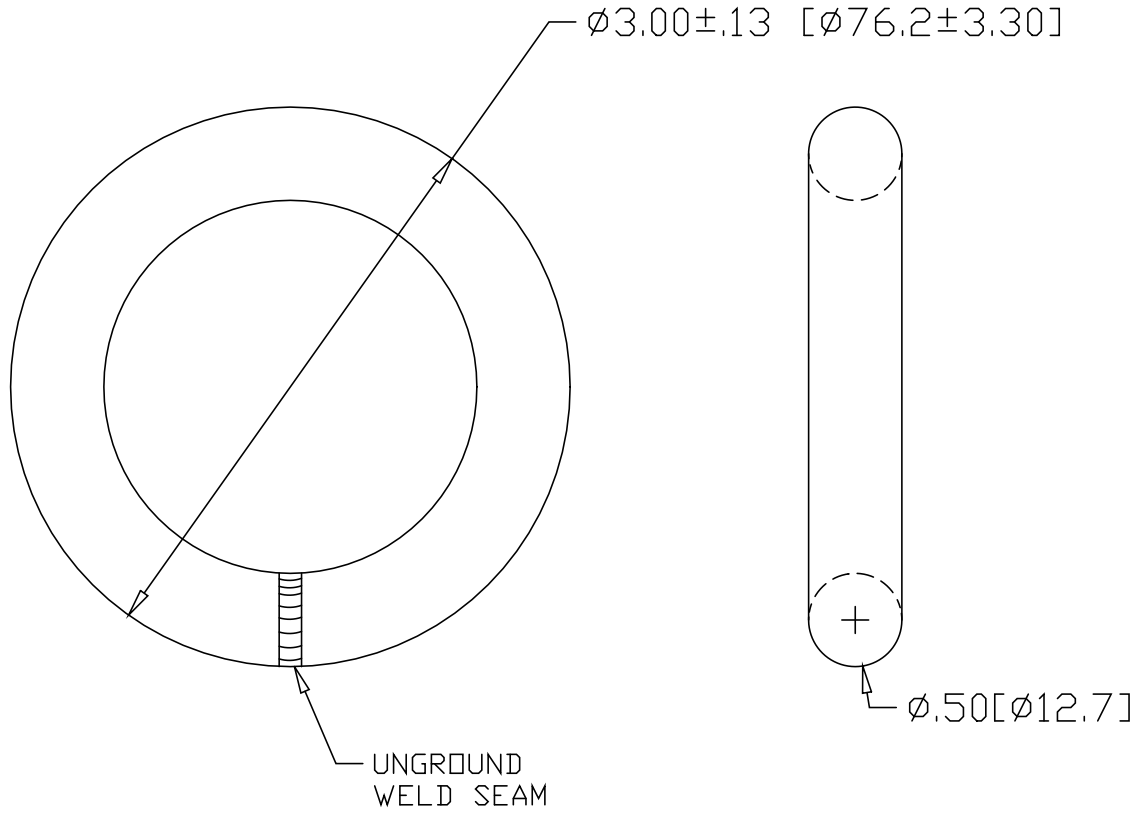

REV
SH
4355
DWG NO

REVISIONS			
REV	DESCRIPTION	DATE	APPROVED



INCHES [MILLIMETERS]

ALTERNATE MATERIAL	PART NUMBER
.50" DIA. (6063-T52) ALUMINUM BAR	4356
.50" DIA. (304) STAINLESS STEEL BAR	4357

PART NAME		.50" X 3.00" OUTSIDE DIAMETER RING	
MATERIAL		.50" DIA. (1018) CR STEEL BAR ASTM A108	
DATE	10/16/98	 THE WAGNER COMPANIES R & B WAGNER, INC. AND J. G. BRAUN CO.	
DRAWN BY	RJF		
FINISH	MILL		
SIZE	WEIGHT	PART NUMBER	REV
A	.42 LBS	4355	