

REV

SH

627

DWG NO

REVISIONS

REV	DESCRIPTION	DATE	APPROVED
-----	-------------	------	----------

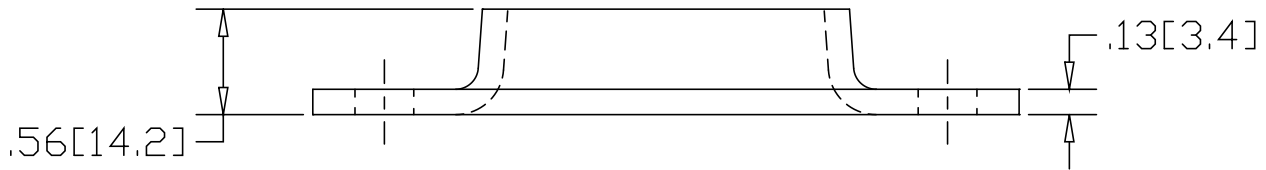
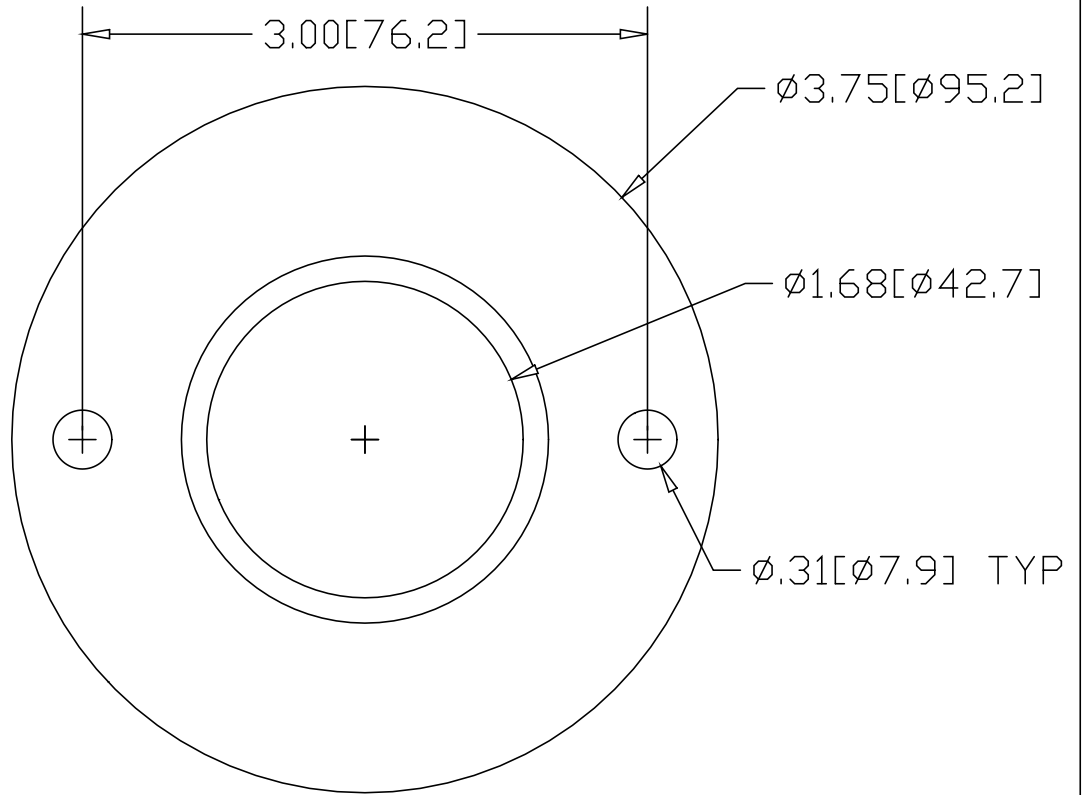

INCHES [MILLIMETERS]

ALTERNATE MATERIAL	PART NUMBER
.125 (3003) ALUMINUM ASTM B209	667
10 GA. (304) STAINLESS STEEL ASTM A240	707

PART NAME 1-1/4" FLAT BASE PIPE FLANGE W/(2) HOLES			
MATERIAL 10 GA. HRP&D STEEL ASTM A-569			
DATE 1/7/99		R & B WAGNER, INC.	
DRAWN BY RJF		PART NUMBER 627	REV
FINISH MILL	SIZE A	WEIGHT .42 lbs	