

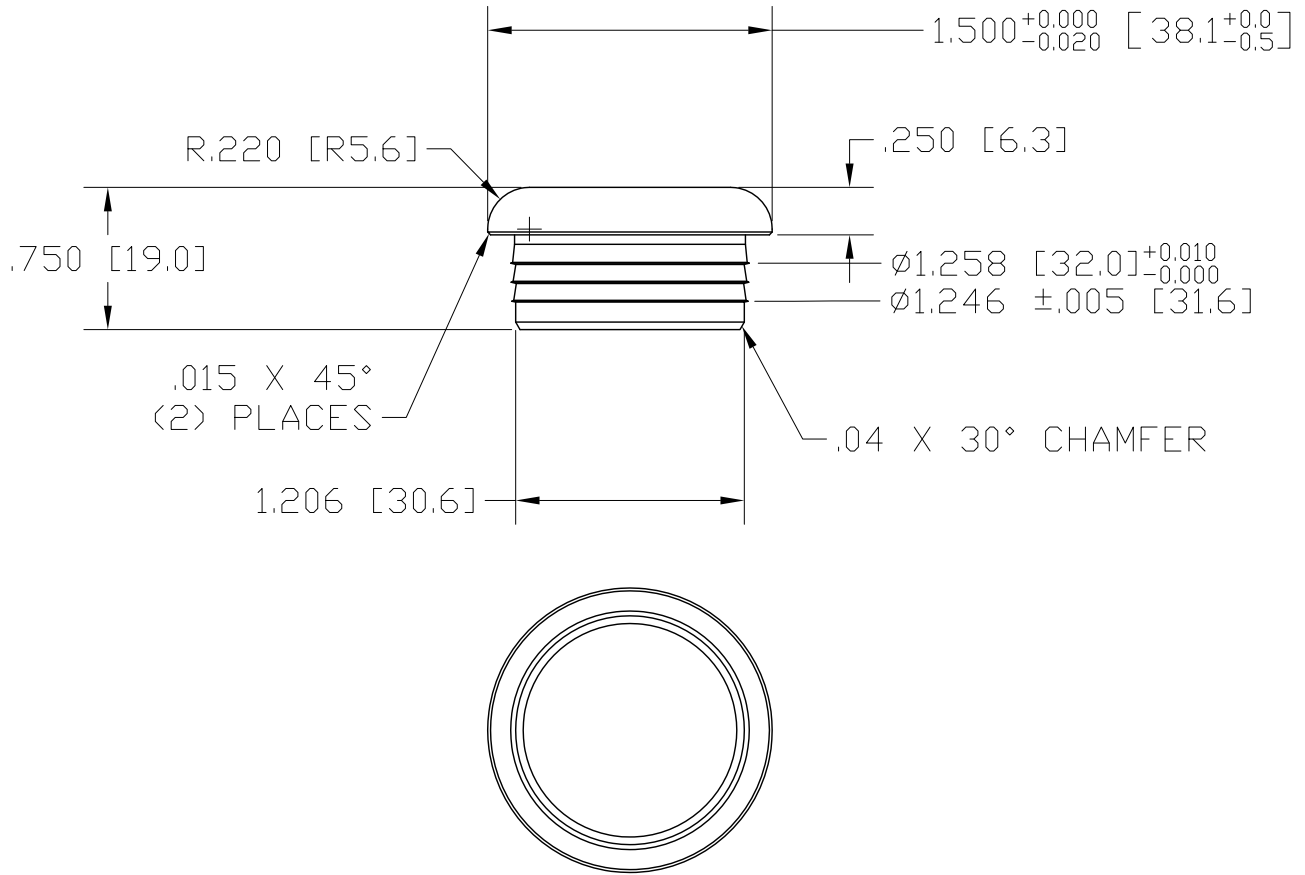

REV A  
SH  
DWG NO 3242DM

REVISIONS			
REV	DESCRIPTION	DATE	APPROVED
A	OD TOLERANCE WAS +0/-0.010	10/24/13	RJF



INCHES [MILLIMETERS]

PART NAME		1.50" OD TUBE SIZE TYPE-G MACHINED DRIVE-ON CAP		
MATERIAL		6063-T52 ALUMINUM		
DATE	04/20/05	 <b>THE WAGNER COMPANIES</b> R & B WAGNER, INC. AND J. G. BRAUN CO.		
DRAWN BY	RJF			
FINISH	MILL	SIZE	WEIGHT	PART NUMBER
		A	.17 LBS	3242DM
				REV A