

REV
SH
1444
DWG NO

REVISIONS			
REV	DESCRIPTION	DATE	APPROVED

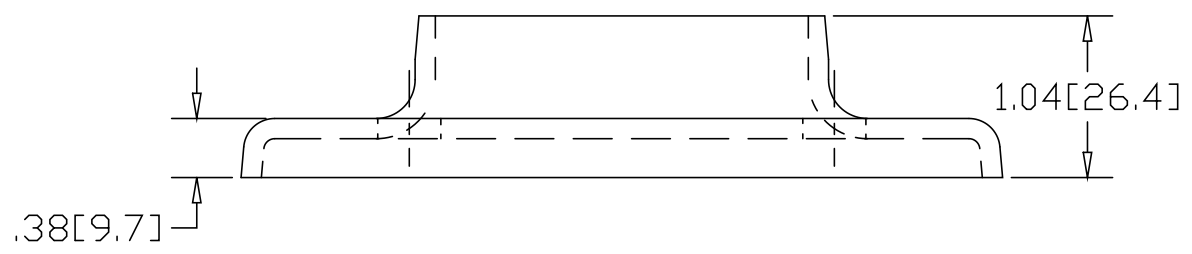
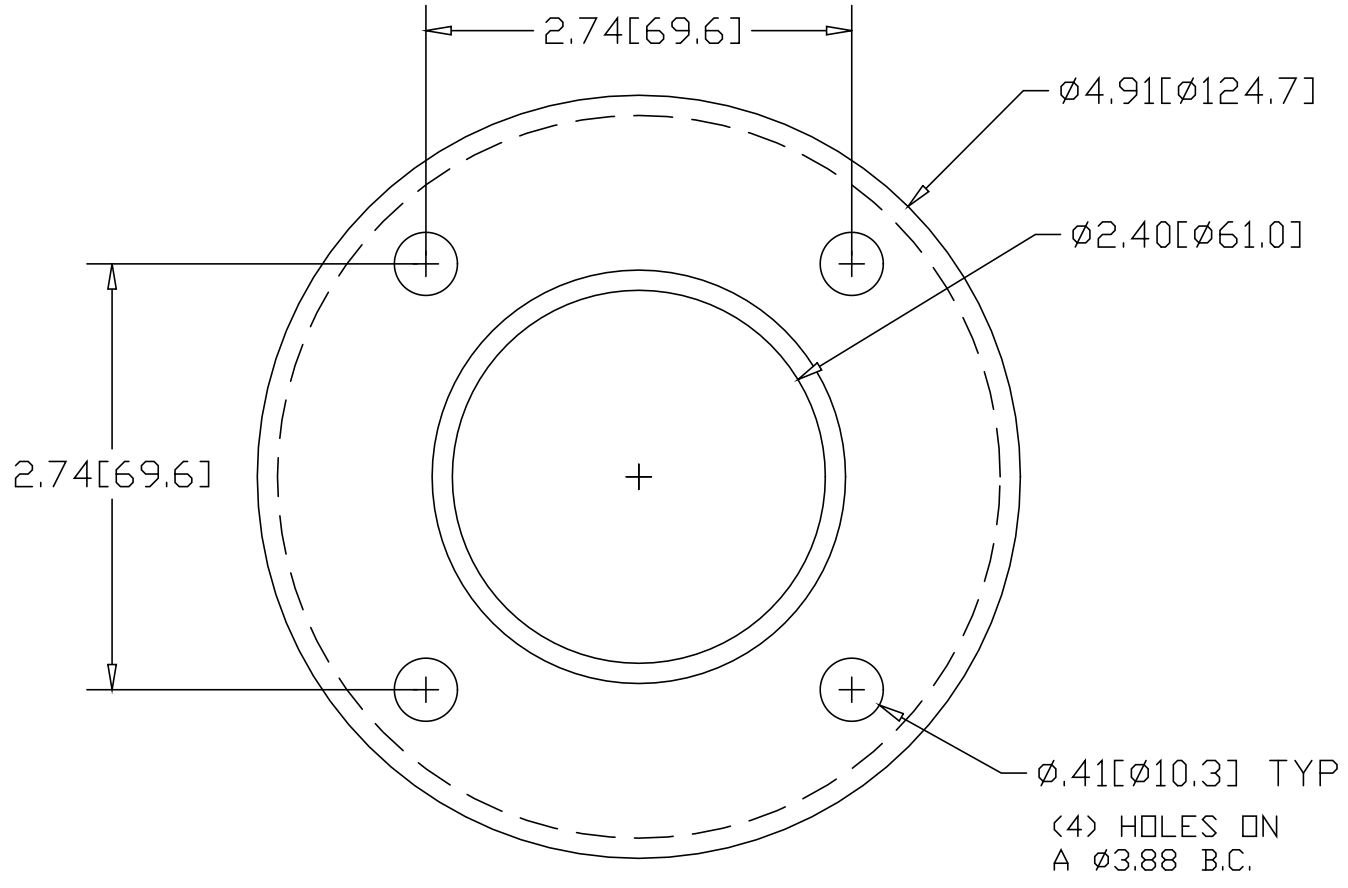

INCHES [MILLIMETERS]

*USE WITH ANCHOR PLATE
 #B1448 IN STEEL
 #PLB1448 ZINC PLATED STEEL
 #B1548 IN STAINLESS

ALTERNATE MATERIAL	PART NUMBER
.125 (3003) ALUMINUM ASTM B209	1484
10 GA. (304) STAINLESS STEEL ASTM A240	1544

PART NAME				2" PIPE HEAVY BASE FLANGE W/(4) HOLES	
MATERIAL				10 GA. HRP&D STEEL ASTM A569	
DATE	9/14/94				
DRAWN BY	RJF				
FINISH	MILL				
SIZE	A	WEIGHT	.72 LBS	PART NUMBER	1444
				REV	