

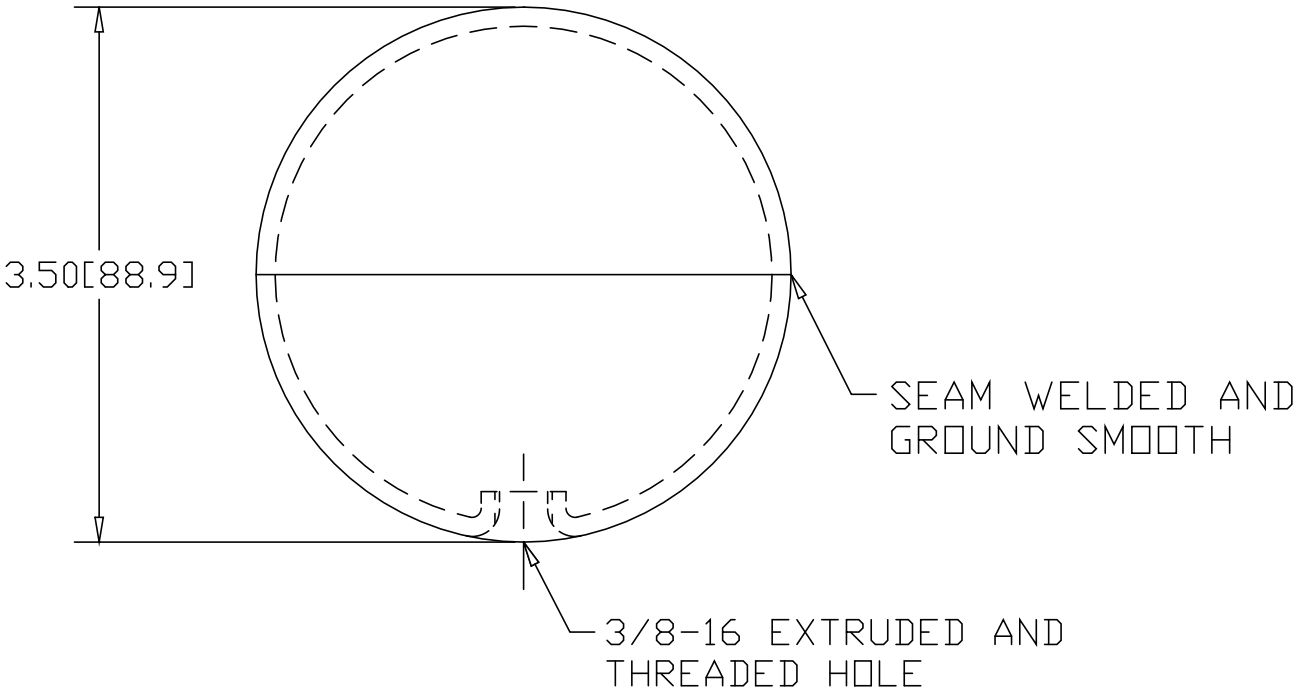

REV  
SH  
4140H  
DWG NO

REVISIONS			
REV	DESCRIPTION	DATE	APPROVED



INCHES [MILLIMETERS]

ALTERNATE MATERIAL	PART NUMBER
.125 (3003) ALUMINUM SHEET ASTM B209	4142H
11 GA. (.1200) 304 STAINLESS STEEL A240	4144H
.125 (260) BRASS	4146H
.125 (655) SILICON BRONZE	SB4140H

PART NAME 3.50" DIAMETER HOLLOW BALL WITH 3/8-16 TAPPED HOLE			
MATERIAL 11 GA. (.1196) HRP&D STEEL SHEET ASTM A569			
DATE 1/4/00		<b>THE WAGNER COMPANIES</b> R & B WAGNER, INC. AND J. G. BRAUN CO.	
DRAWN BY RJF			
FINISH MILL			
SIZE A	WEIGHT 1.08 LBS	PART NUMBER 4140H	REV