

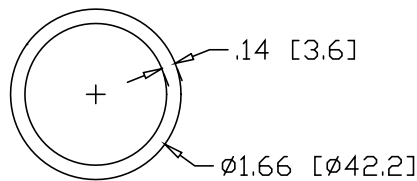

REV
SH
DWG NO 5631-2

| REVISIONS | | | |
|-----------|-------------|------|----------|
| REV | DESCRIPTION | DATE | APPROVED |

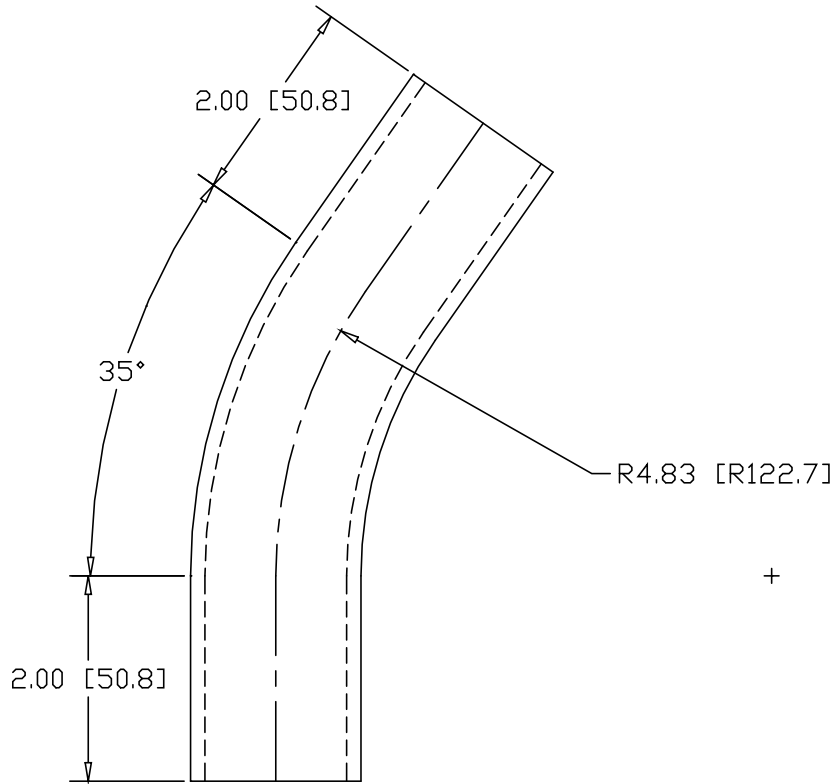

INCHES [MILLIMETERS]

| | | | |
|---|--------|---|----------|
| PART NAME 1-1/4" PIPE SIZE 35° ELL X 4" I.R. W/ (2) 2" TANGENTS | | | |
| MATERIAL 1-1/4" SCH 40 A53 STEEL PIPE | | | |
| DATE | 4/5/96 |  THE WAGNER COMPANIES R & B WAGNER, INC. AND J. G. BRAUN CO. | |
| DRAWN BY | RJF | | |
| FINISH | MILL | | |
| SIZE | A | WEIGHT | 1.31 LBS |
| PART NUMBER | | 5631-2 | |
| | | | REV |