

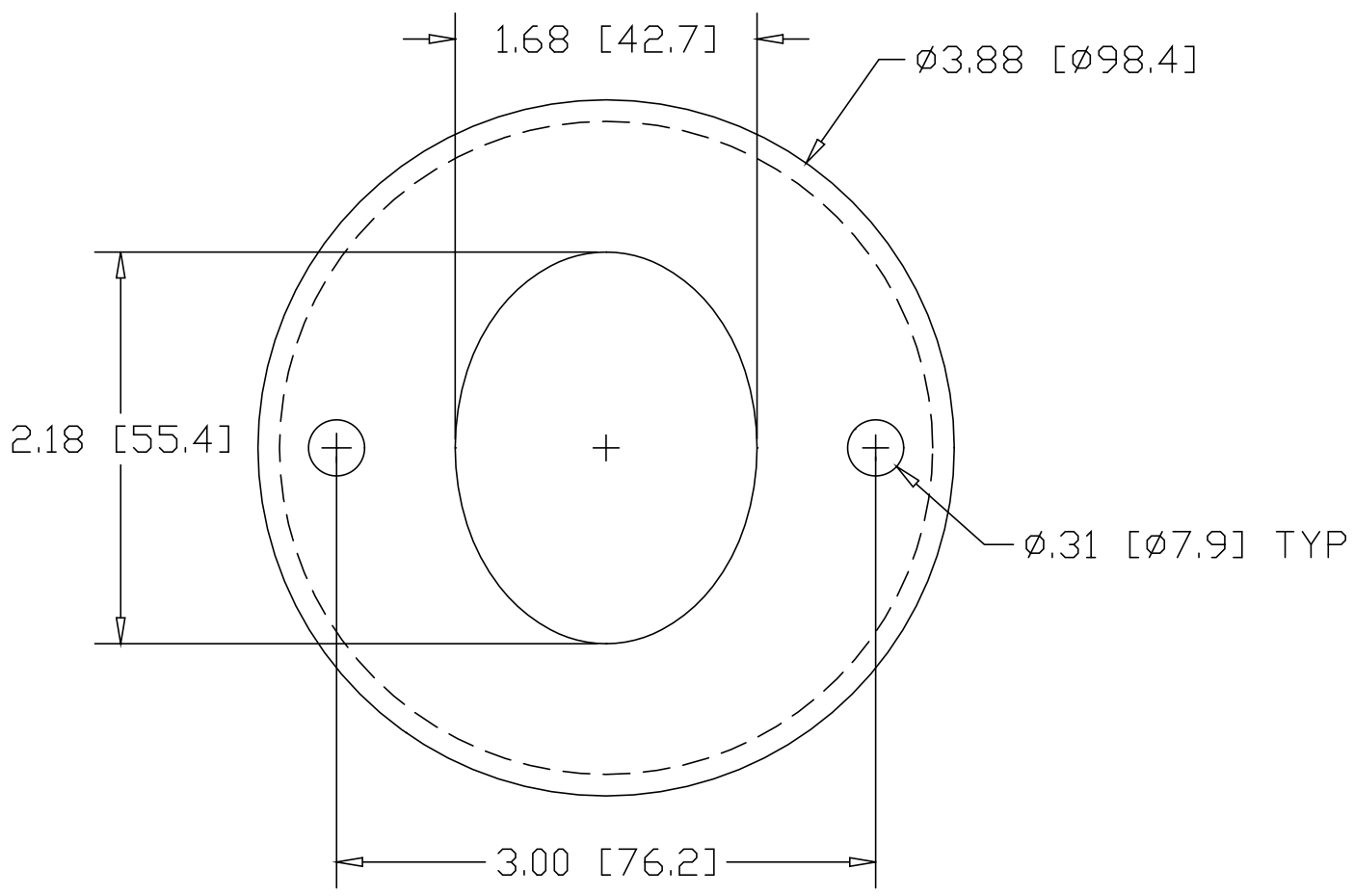

REV  
SH  
2827  
DWG NO

REVISIONS			
REV	DESCRIPTION	DATE	APPROVED



INCHES [MILLIMETERS]

ALTERNATE MATERIAL	PART NUMBER
.125 (3003) ALUMINUM ASTM B209	2867
10 GA. (304) STAINLESS STEEL ASTM A240	2907

PART NAME 1-1/4" PIPE HEAVY FLUSH BASE BEVELED FLANGE W/(2) HOLES			
MATERIAL 10 GA. HRP&D STEEL ASTM A569			
DATE 9/6/94		<b>THE WAGNER COMPANIES</b> R & B WAGNER, INC. AND J. G. BRAUN CO.	
DRAWN BY RJF			
FINISH MILL			
SIZE A	WEIGHT .5 LBS	PART NUMBER 2827	REV