

REV  
SH  
1445  
DWG NO

REVISIONS			
REV	DESCRIPTION	DATE	APPROVED

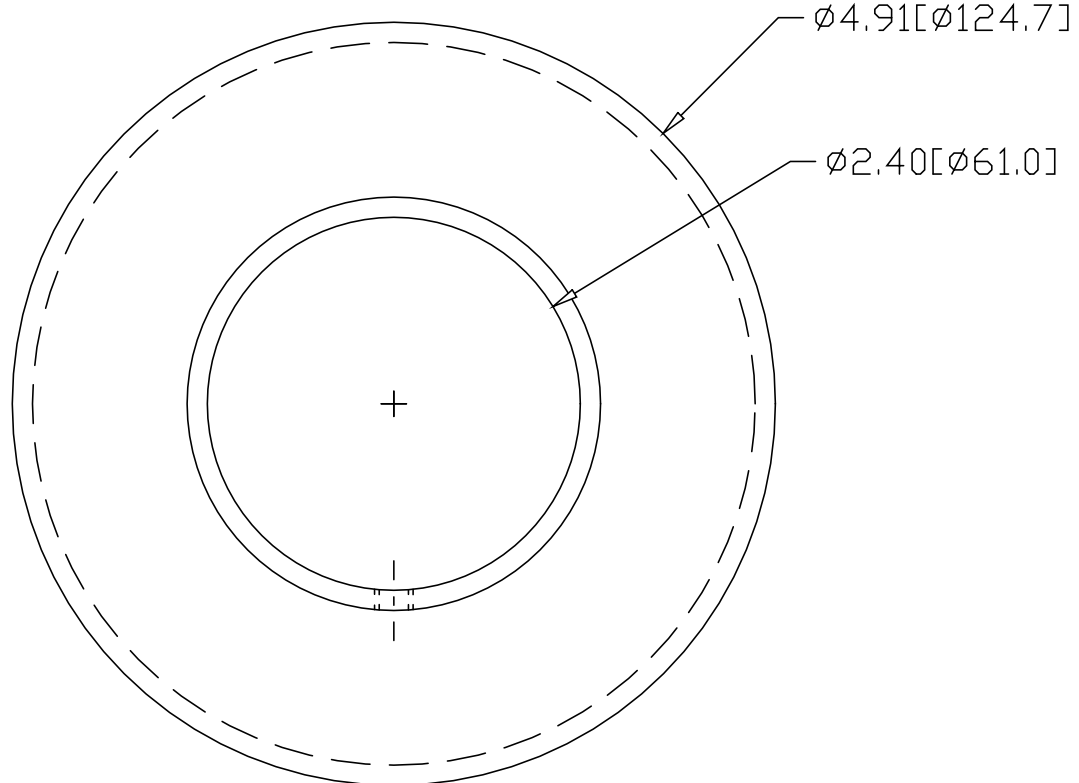

1/4-20  
SET-SCREW

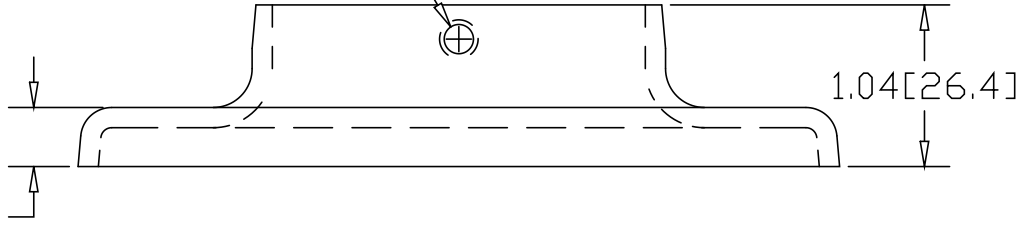

INCHES [MILLIMETERS]

ALTERNATE MATERIAL	PART NUMBER
.125 (3003) ALUMINUM ASTM B209	1485
10 GA. (304) STAINLESS STEEL ASTM A240	1545

PART NAME 2" PIPE HEAVY BASE FLANGE WITH SET-SCREW				
MATERIAL 10 GA. HRP&D STEEL ASTM A569				
DATE 9/14/94	 <b>R &amp; B WAGNER, INC.</b>			
DRAWN BY RJF				
FINISH MILL	SIZE A	WEIGHT .72 LBS	PART NUMBER 1445	REV