

REV
SH
1166-2
DWG NO

REVISIONS			
REV	DESCRIPTION	DATE	APPROVED

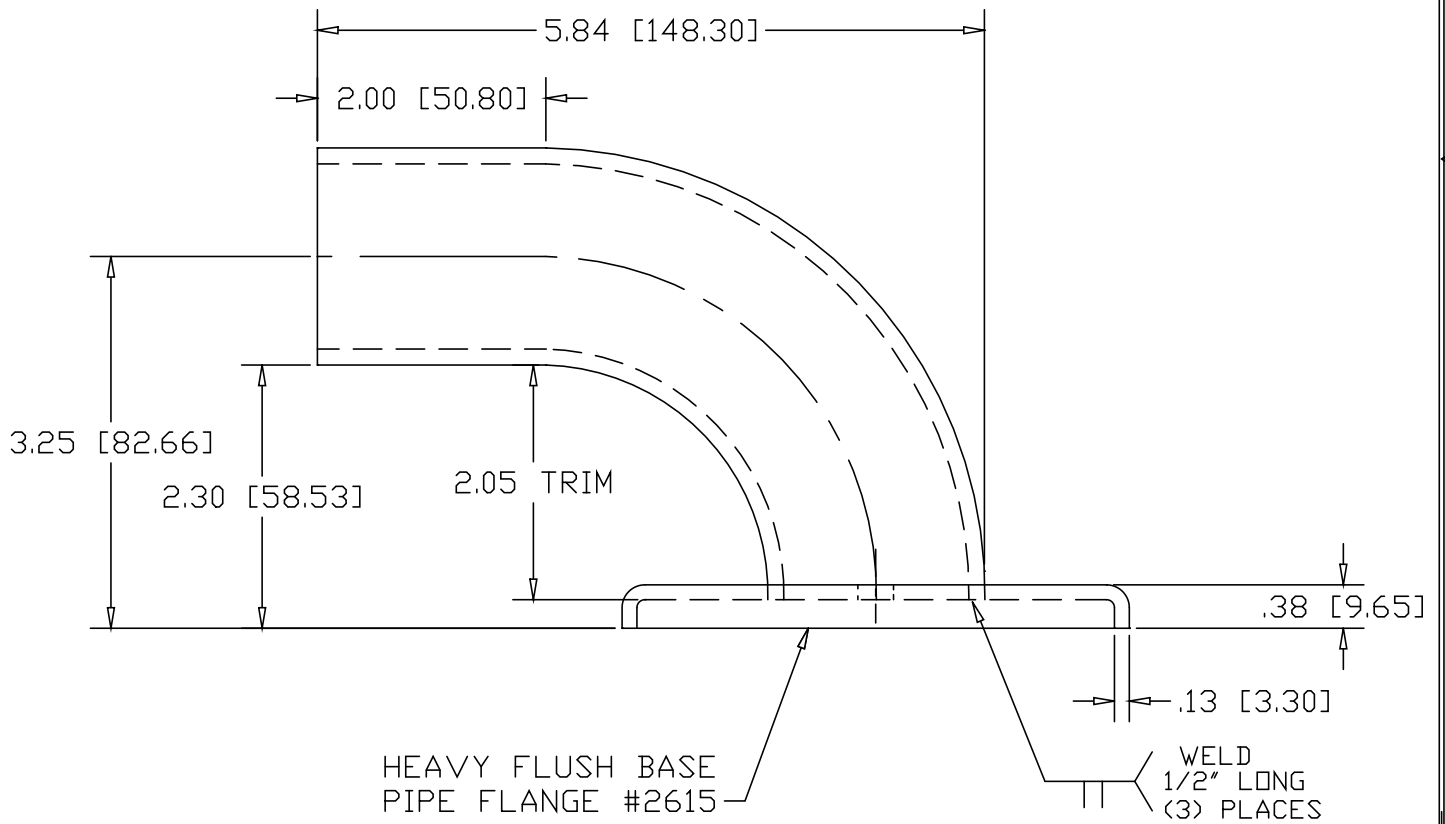
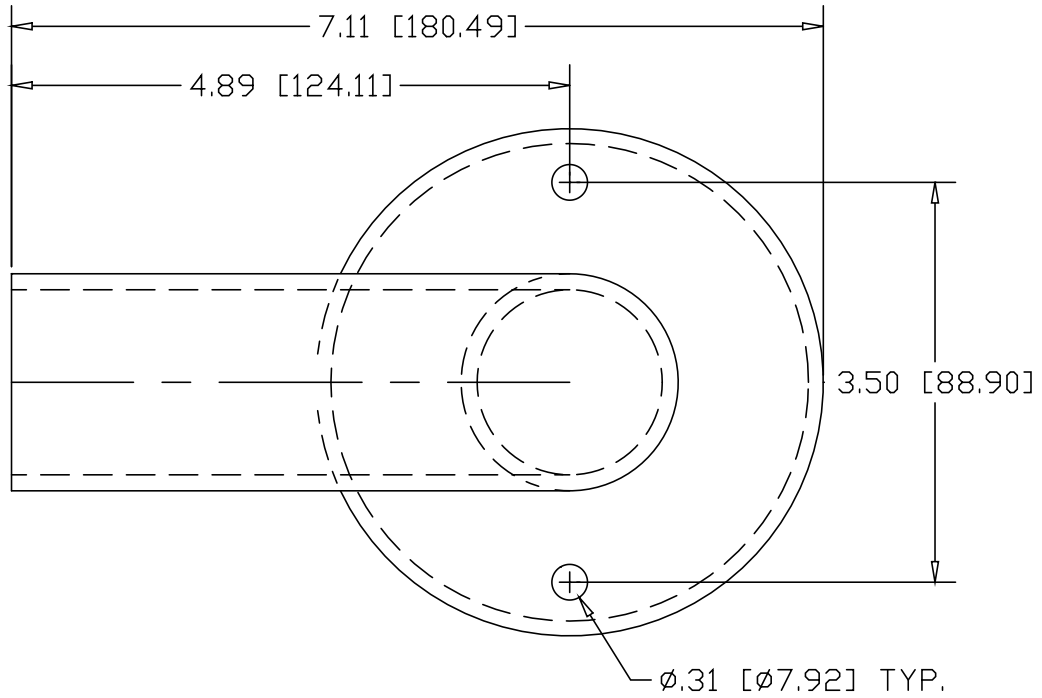

PART NAME 1-1/2" PIPE SIZE X 3.25"CL WALL RETURN W/2 HOLES			
MATERIAL STAINLESS STEEL ASTM-A312			
DATE 1/10/07		THE WAGNER COMPANIES R & B WAGNER, INC. AND J. G. BRAUN CO.	
DRAWN BY RDC			
FINISH #4 SATIN			
SIZE A	WEIGHT	PART NUMBER 1166-2	REV