

REV

SH

DWG NO 9622

DWG NO

REVISIONS

REV	DESCRIPTION	DATE	APPROVED
-----	-------------	------	----------

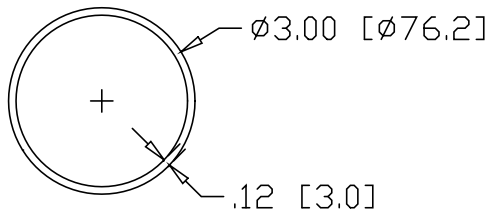
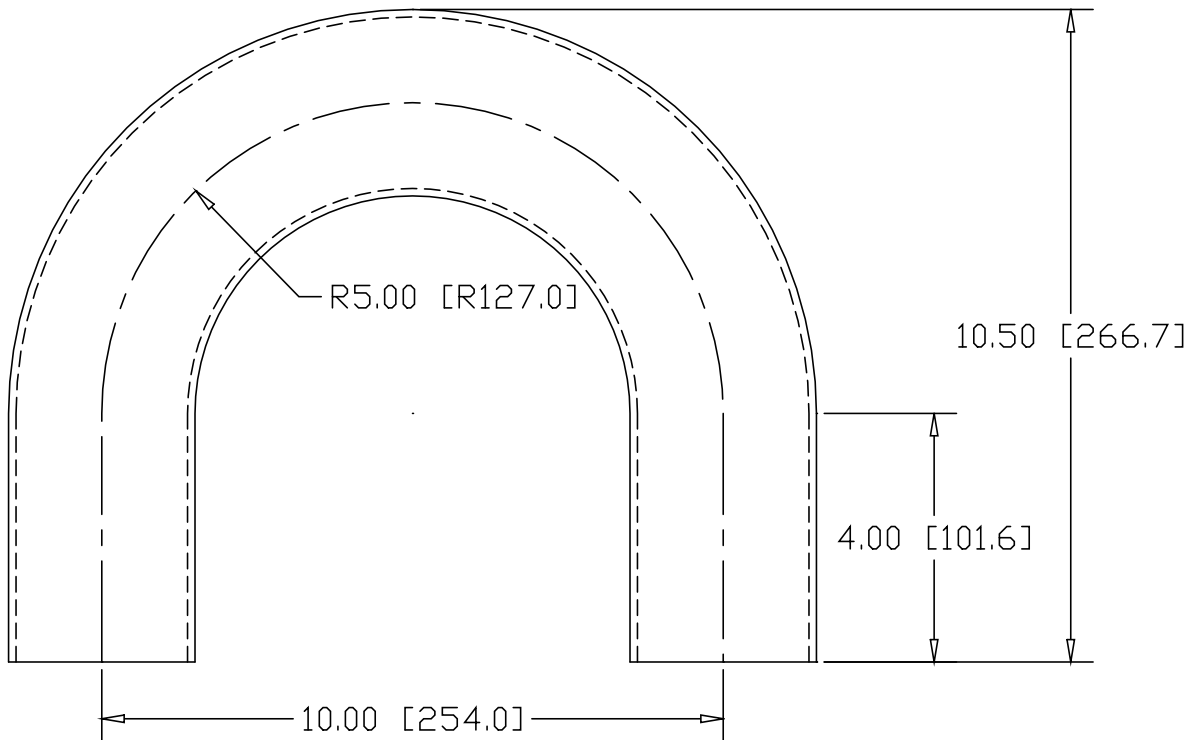

INCHES [MILLIMETERS]

ALTERNATE MATERIAL	PART NUMBER
3.00" OD X .125W 6061 ALUMINUM TUBE	9625
3.00" OD X .120W 304 STAINLESS STEEL TUBE	9627
3.00" OD X .125W 330 BRASS TUBE	9629

PART NAME 3.00" OD TUBE SIZE 180° ELL X 5" CLR W/⟨2⟩ 4" TANGENTS			
MATERIAL 3.00" OD X .120W STEEL TUBE			
DATE 9/2/03	 <b>THE WAGNER COMPANIES</b> R & B WAGNER, INC. AND J. G. BRAUN CO.		
DRAWN BY RJF			
FINISH MILL			
SIZE A	WEIGHT 7.29 LBS	PART NUMBER 9622	REV