

REV
SH
1683
DWG NO

REVISIONS			
REV	DESCRIPTION	DATE	APPROVED

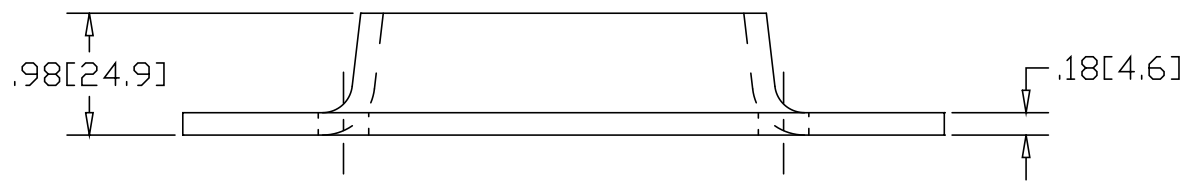
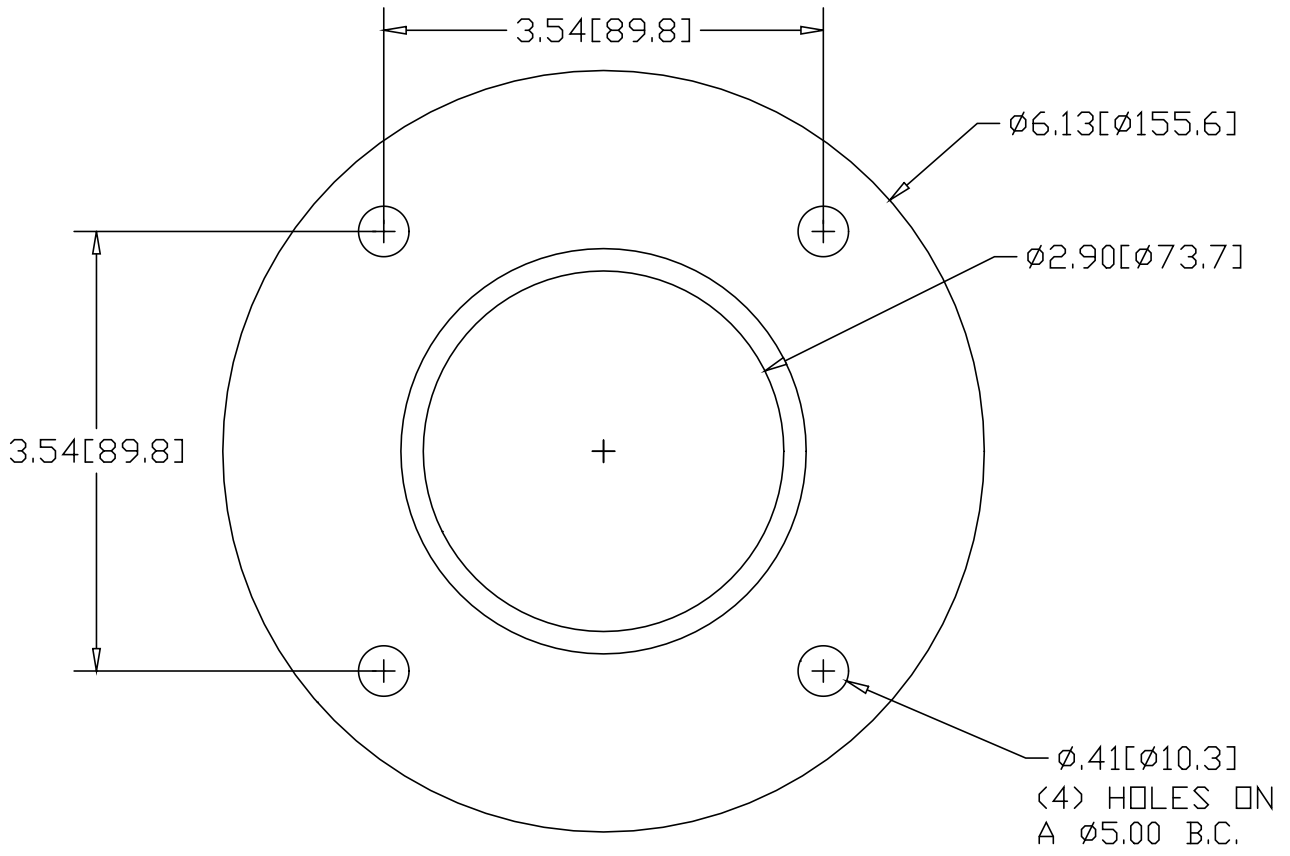

INCHES [MILLIMETERS]

*USE WITH ANCHOR PLATE
#B1688 IN STEEL
#B1698 IN ALUMINUM

ALTERNATE MATERIAL	PART NUMBER
.19 (3003) ALUMINUM ASTM B-209	1693

PART NAME		2-1/2" PIPE SIZE EXTRA HEAVY FLANGE W/(4) HOLES					
MATERIAL		7 GA. HRP&D STEEL ASTM A-569					
DATE	3/3/95						
DRAWN BY	RJF						
FINISH	MILL						
SIZE	A	WEIGHT	1.33 LBS	PART NUMBER	1683	REV	