

REV  
SH  
5727  
DWG NO

REVISIONS			
REV	DESCRIPTION	DATE	APPROVED

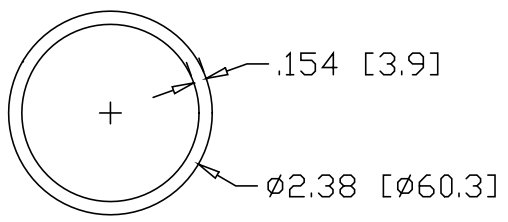
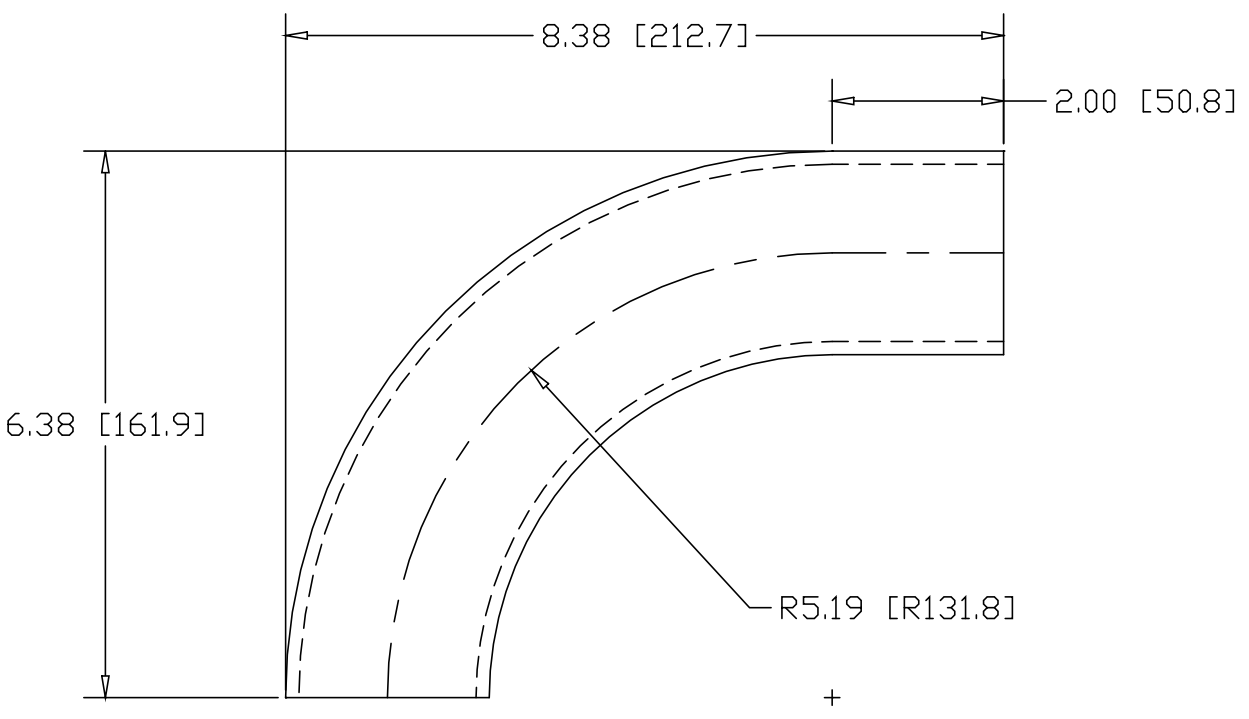

INCHES [MILLIMETERS]

ALTERNATE MATERIAL	PART NUMBER
2" SCH 40 (6063) ALUMINUM PIPE	5741
2" SCH 40 (304) STAINLESS STEEL PIPE	5755

PART NAME 2" PIPE SIZE 90° X 4" I.R. ELL W/(1) 2" TANGENT			
MATERIAL 2" SCH 40 STEEL PIPE			
DATE 4/9/96	<b>WAGNER</b> R & B WAGNER, INC.		
DRAWN BY RJF			
FINISH MILL		SIZE A	WEIGHT 3.07 LBS
			REV