

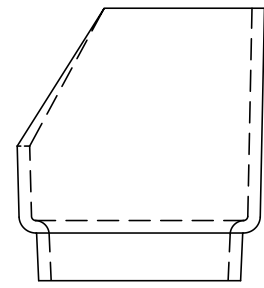

REVISIONS			
REV	DESCRIPTION	DATE	APPROVED

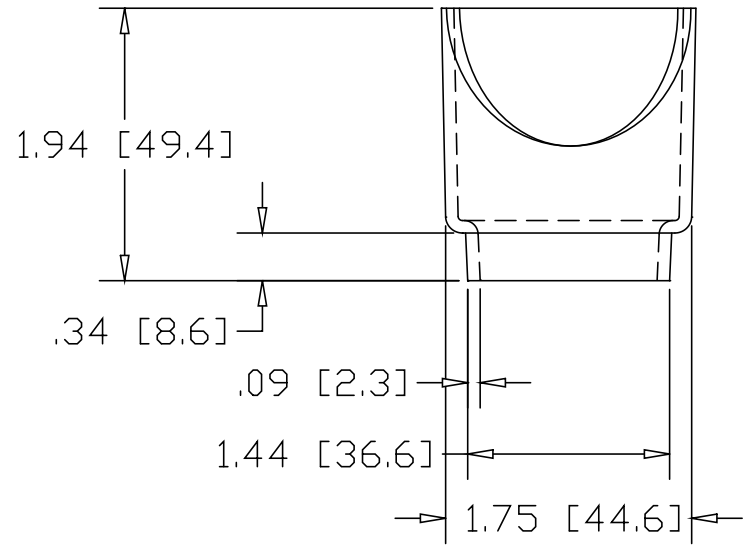
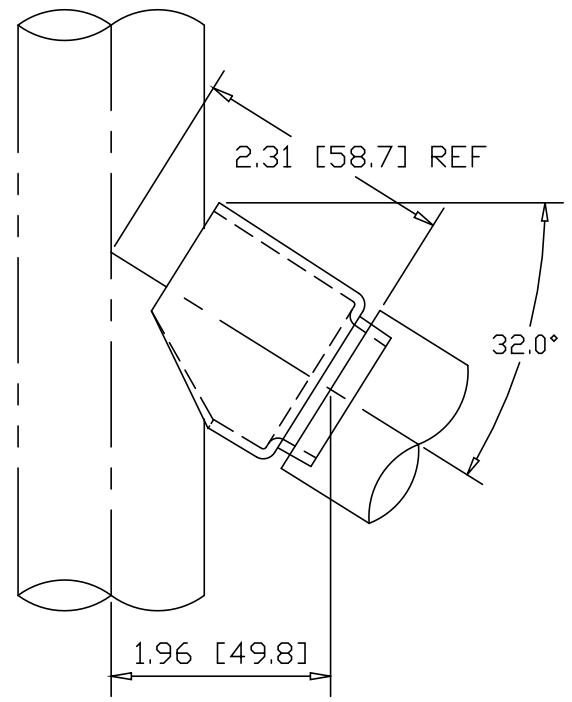
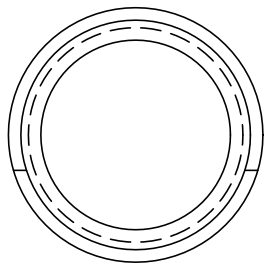
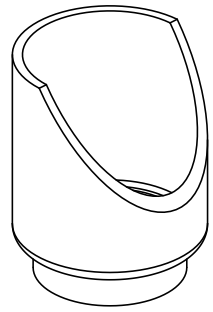

INCHES [MILLIMETERS]

PART NAME 1-1/4" SCH 10 PIPE 32° TYPE "F" COPED WELDING CONNECTOR			
MATERIAL 13 GA. (.089) HRP&D STEEL ASTM A569			
DATE	10/24/01		THE WAGNER COMPANIES R & B WAGNER, INC. AND J. G. BRAUN CO.
DRAWN BY	JAH		
FINISH	MILL	SIZE	WEIGHT
		A	.23 LBS
		PART NUMBER	REV
		1873-L	