

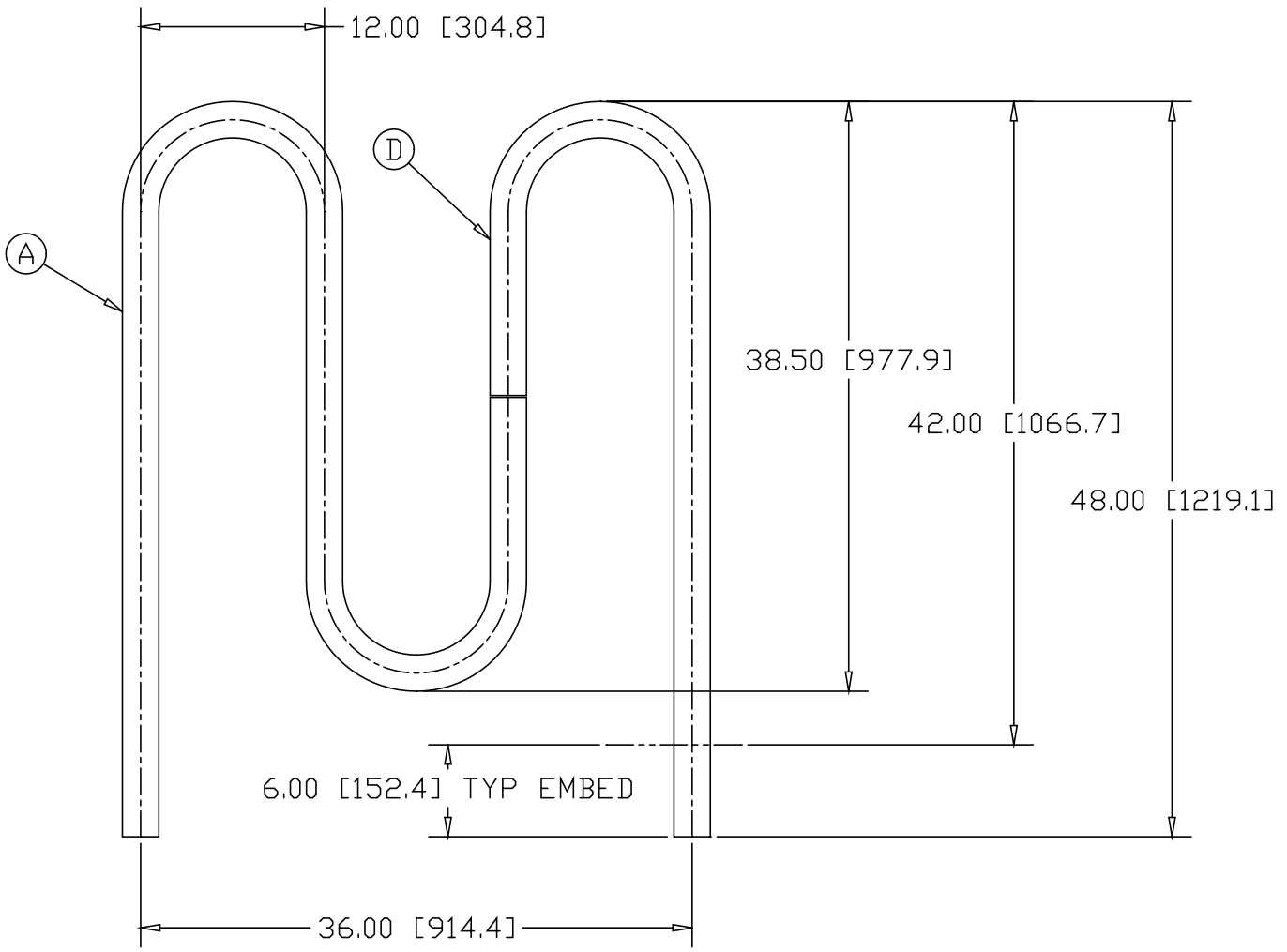

REV
A
SH
SR3M
DWG NO

REVISIONS			
REV	DESCRIPTION	DATE	APPROVED
A	EMBED WAS 10.00, 48.00 WAS 52.00	12/18/06	RJF



INCHES [MILLIMETERS]

ALTERNATE MATERIAL		PART NUMBER	
2" SCH40 STEEL PIPE - GALVANIZED		SR3G	
2" STAINLESS STEEL PIPE SATIN FINISH		SR3SS	
PART NAME 3 LOOP BIKE RACK			
MATERIAL 2" SCH 40 (2.38" O.D.) STEEL PIPE			
DATE 12/29/97		 THE WAGNER COMPANIES R & B WAGNER, INC. AND J. G. BRAUN CO.	
DRAWN BY RJF			
FINISH MILL			
SIZE A	WEIGHT 56.2 lbs	PART NUMBER SR3M	REV A