

REV
SH
1130-2
DWG NO

REVISIONS			
REV	DESCRIPTION	DATE	APPROVED

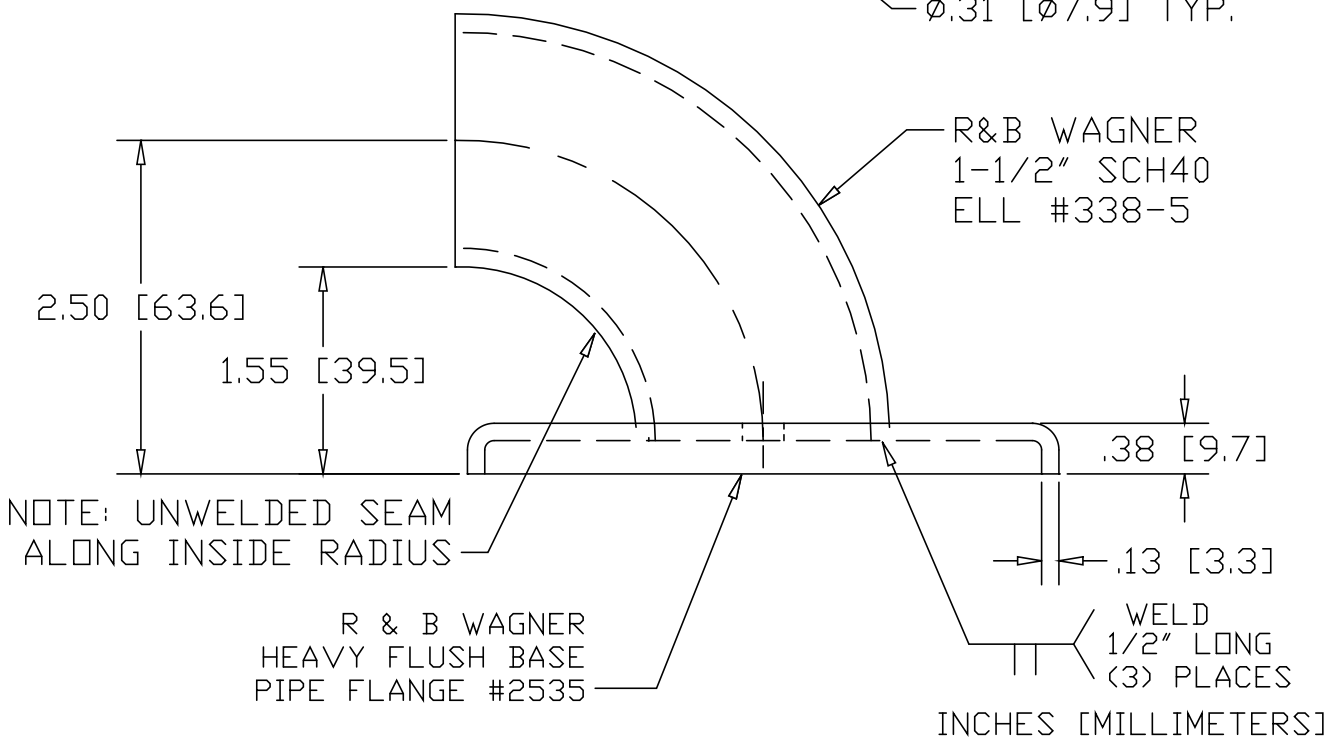
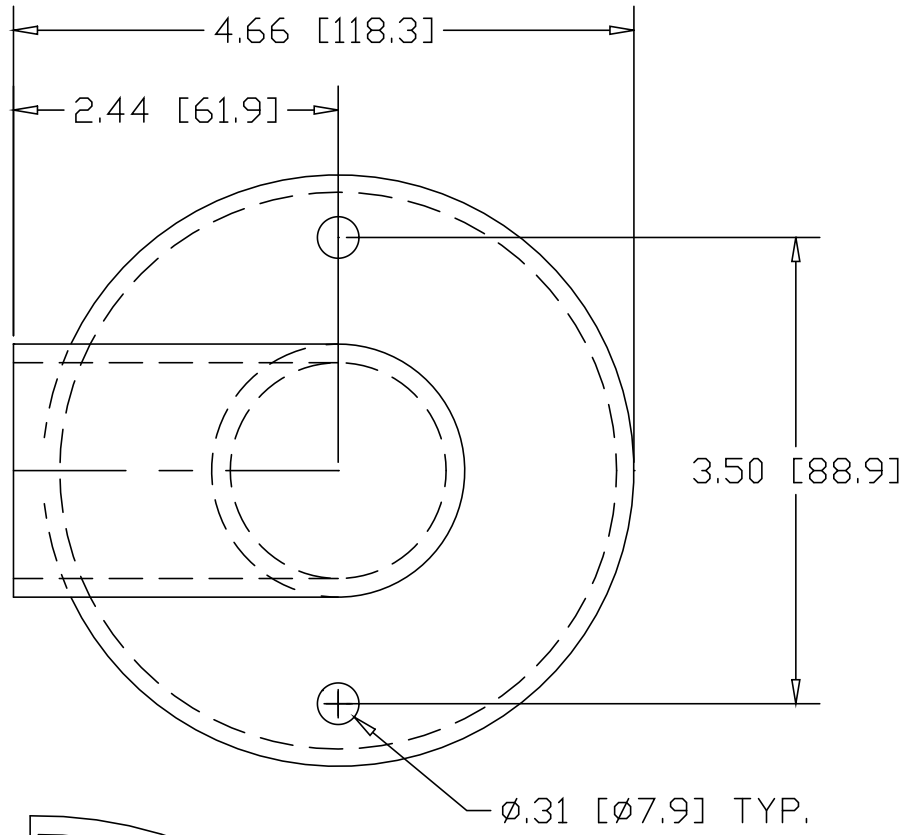

PART NAME		1-1/2" PIPE SIZE 2.50CL WALL RETURN W/2 HOLES	
MATERIAL		STEEL - ASTM A569	
DATE	8/5/93		THE WAGNER COMPANIES R & B WAGNER, INC. AND J. G. BRAUN CO.
DRAWN BY	RJF		
FINISH	MILL		
SIZE	A	WEIGHT	PART NUMBER
			1130-2
			REV