

REV  
SH  
218  
DWG NO

REVISIONS			
REV	DESCRIPTION	DATE	APPROVED

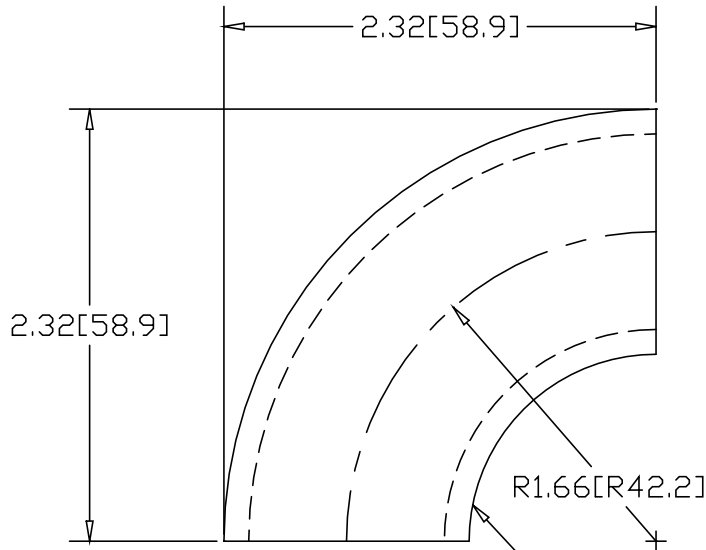

NOTE: UNWELDED SEAM ALONG INSIDE RADIUS

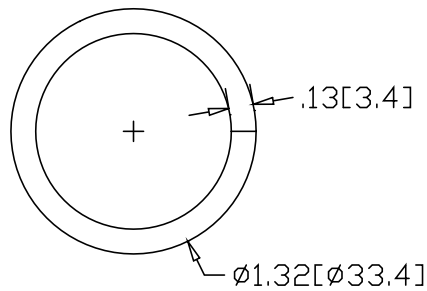

INCHES [MILLIMETERS]

ALTERNATE MATERIAL	PART NUMBER
.125 (3003) ALUMINUM ASTM B209	242
10 GA. (304) STAINLESS STEEL ASTM A240	219-S

PART NAME		1" PIPE 1" I.R. X 90° ELL		
MATERIAL		10 GA. HRP&D STEEL ASTM A569		
DATE	8/17/95	 <b>R &amp; B WAGNER, INC.</b>		
DRAWN BY	RJF			
FINISH	MILL	SIZE	WEIGHT	PART NUMBER
		A	.40 LBS	218
				REV