

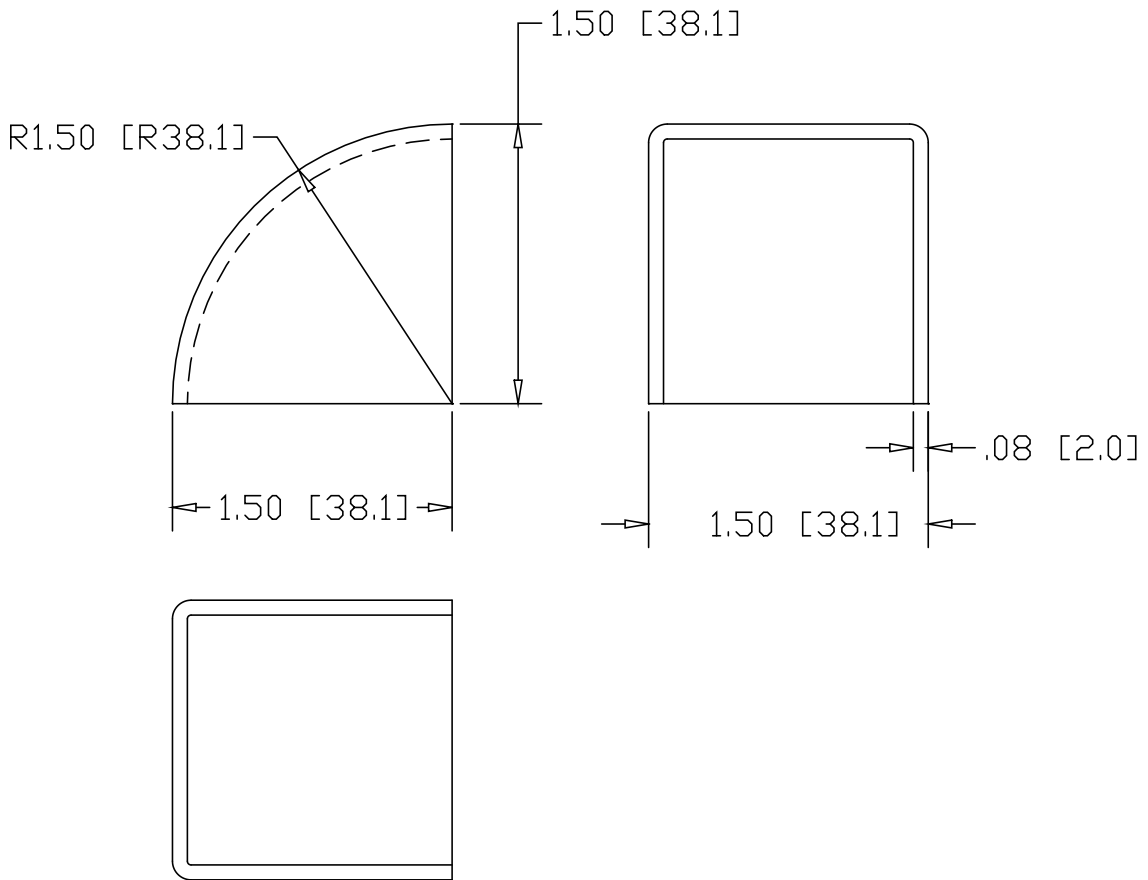

REV  
SH  
9220  
DWG NO

| REVISIONS |             |      |          |
|-----------|-------------|------|----------|
| REV       | DESCRIPTION | DATE | APPROVED |



INCHES [MILLIMETERS]

| ALTERNATE MATERIAL             | PART NUMBER |
|--------------------------------|-------------|
| .080 (3003) ALUMINUM ASTM B209 | 9221        |
| 14 GA. (304) STAINLESS STEEL   | 9222        |
| .083 (260) BRASS               | 9223        |

|           |         |   |         |
|-----------|---------|---|---------|
| PART NAME |         | 1-1/2" SQUARE TUBE CORNER   |         |
| MATERIAL  |         | 14 GA. HRP&D STEEL ASTM A569  |         |
| DATE      | 8/26/96 |  <b>THE WAGNER COMPANIES</b><br>R & B WAGNER, INC. AND J. G. BRAUN CO. |         |
| DRAWN BY  | RJF     |   |         |
| FINISH    | MILL    |   |         |
| SIZE      | A       | WEIGHT  | .13 LBS |
|           |         | PART NUMBER   | 9220    |
|           |         | REV   |         |