

REV  
SH  
1103-1  
DWG NO

REVISIONS			
REV	DESCRIPTION	DATE	APPROVED

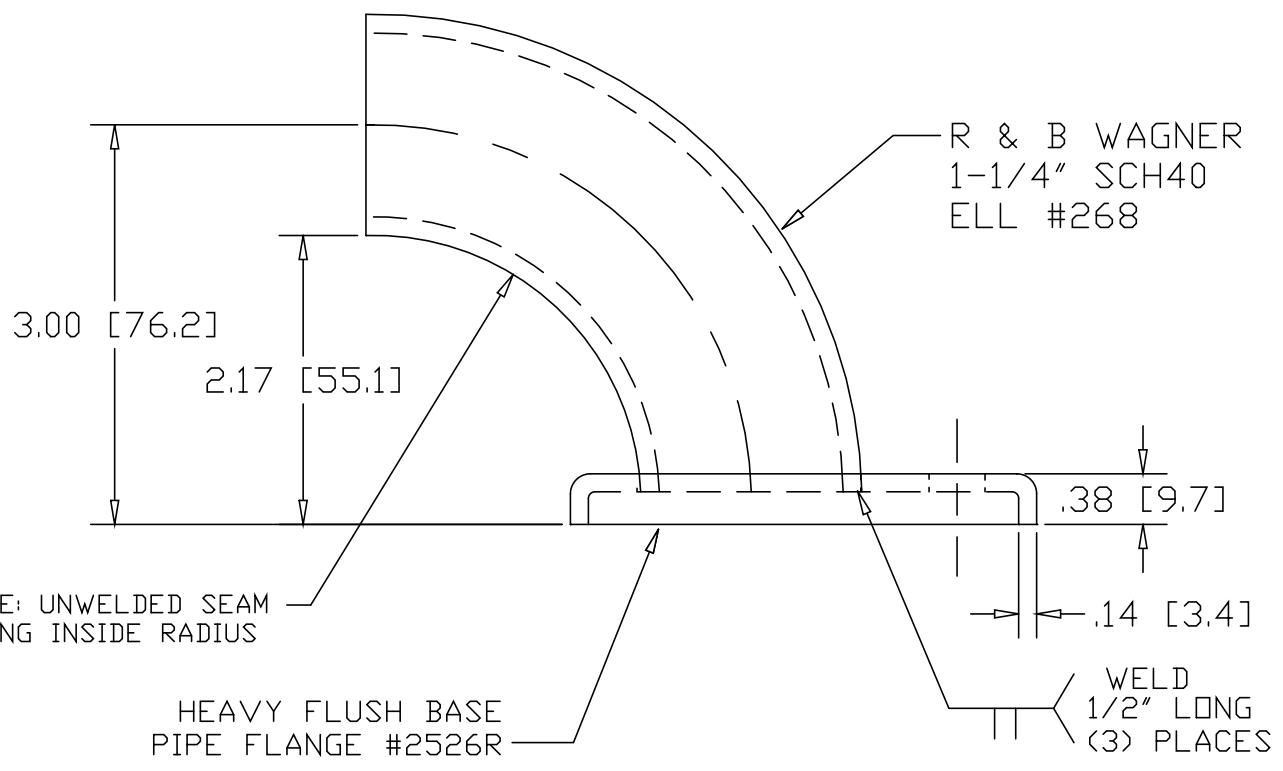
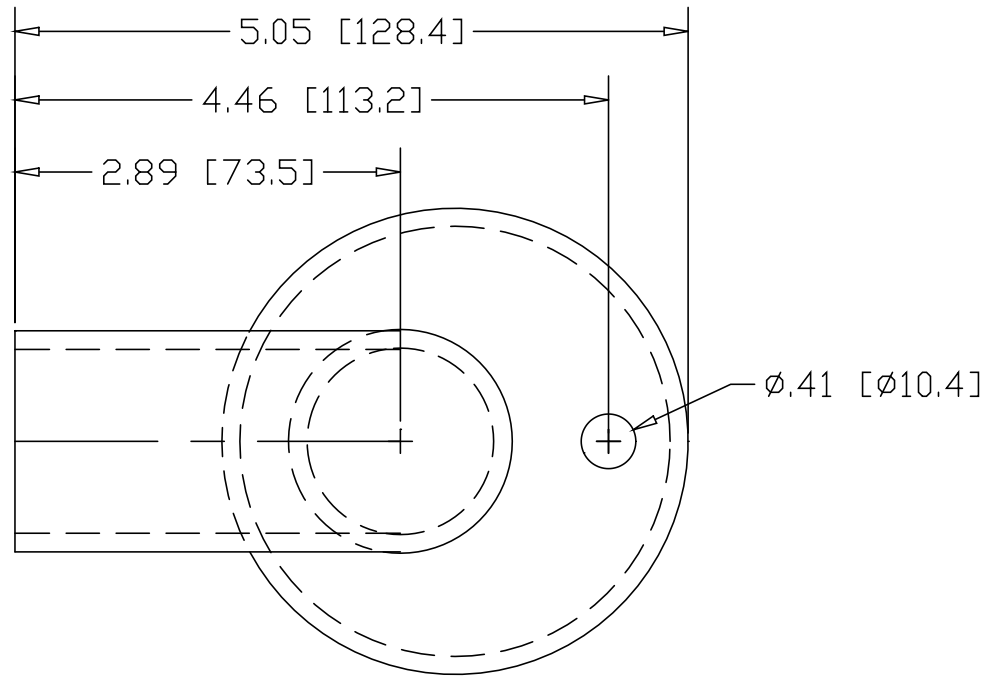

INCHES [MILLIMETERS]

PART NAME		1-1/4" PIPE SIZE X 3.00CL WALL RETURN W/1 HOLE		
MATERIAL		ASTM A569 - STEEL		
DATE	8/07/02		THE WAGNER COMPANIES R & B WAGNER, INC. AND J. G. BRAUN CO.	
DRAWN BY	JAH			
FINISH	MILL			
SIZE	A	WEIGHT	PART NUMBER	1103-1
				REV