

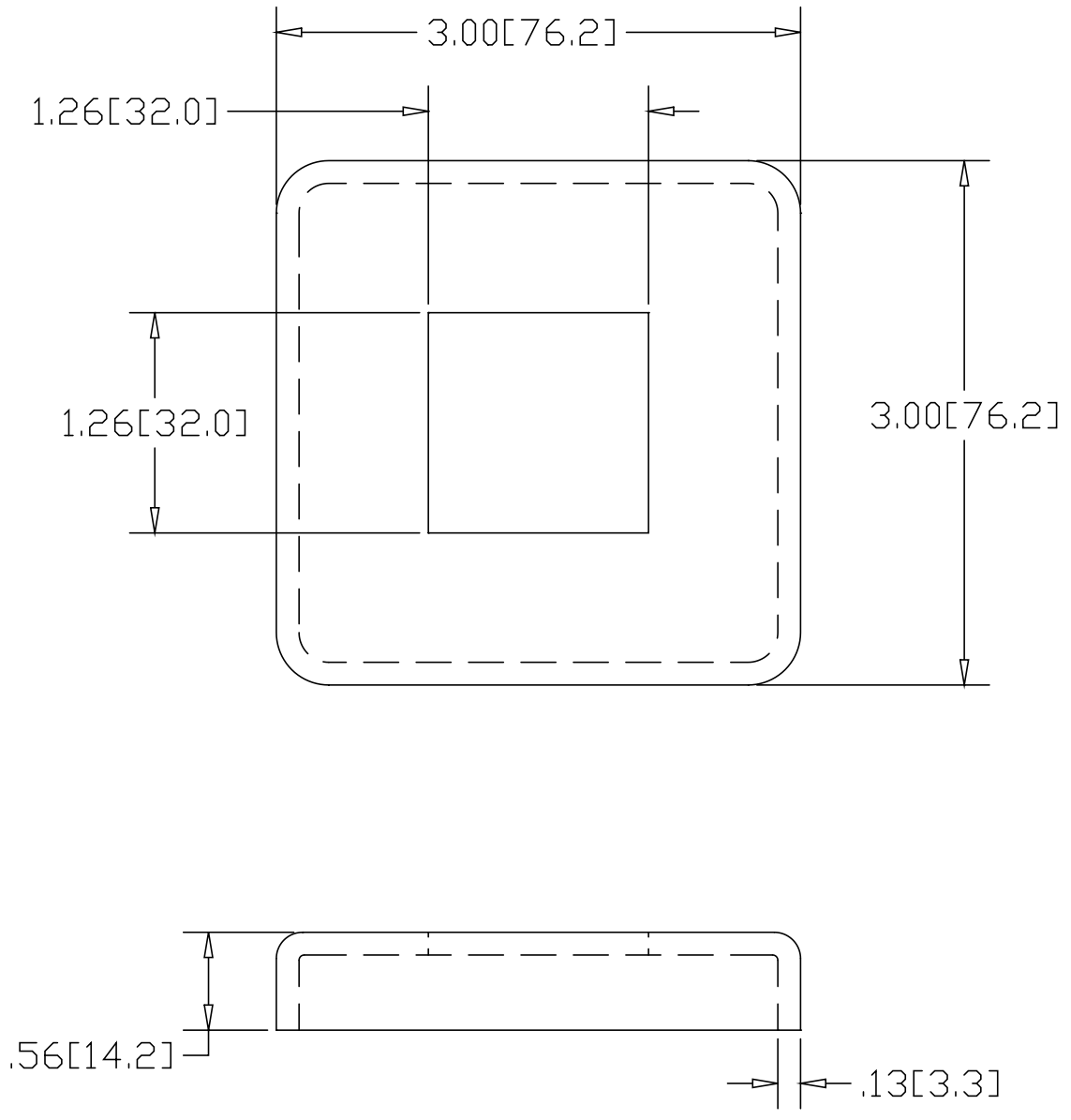

REV
SH
DWG NO 8715

REVISIONS			
REV	DESCRIPTION	DATE	APPROVED



INCHES [MILLIMETERS]

ALTERNATE MATERIAL	PART NUMBER
.125 (3003) ALUMINUM ASTM B209	8785
10 GA. (304) STAINLESS STEEL ASTM A240	8855

PART NAME		1-1/4" SQUARE TUBE HFB FLANGE			
MATERIAL		10 GA. HRP&O STEEL ASTM A569			
DATE	6/20/95	 R & B WAGNER, INC.			
DRAWN BY	RJF				
FINISH	MILL	SIZE	WEIGHT	PART NUMBER	REV
		A	.42 LBS	8715	