

REV
SH
1447T
DWG NO

REVISIONS			
REV	DESCRIPTION	DATE	APPROVED

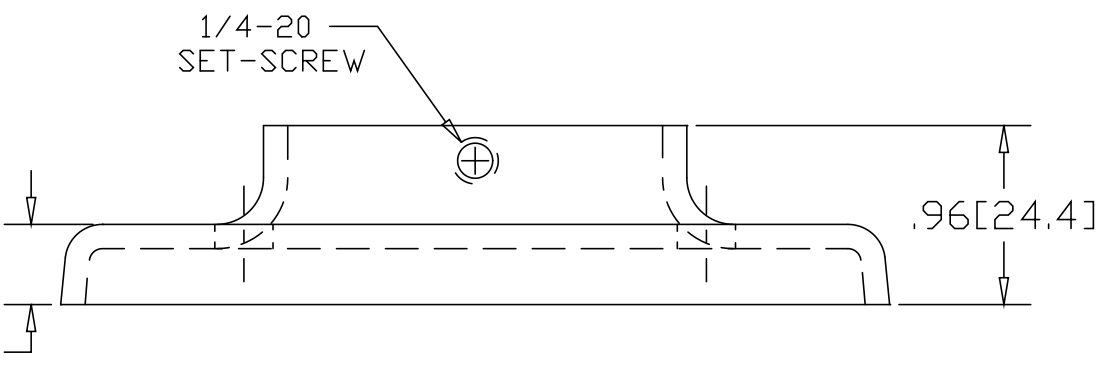
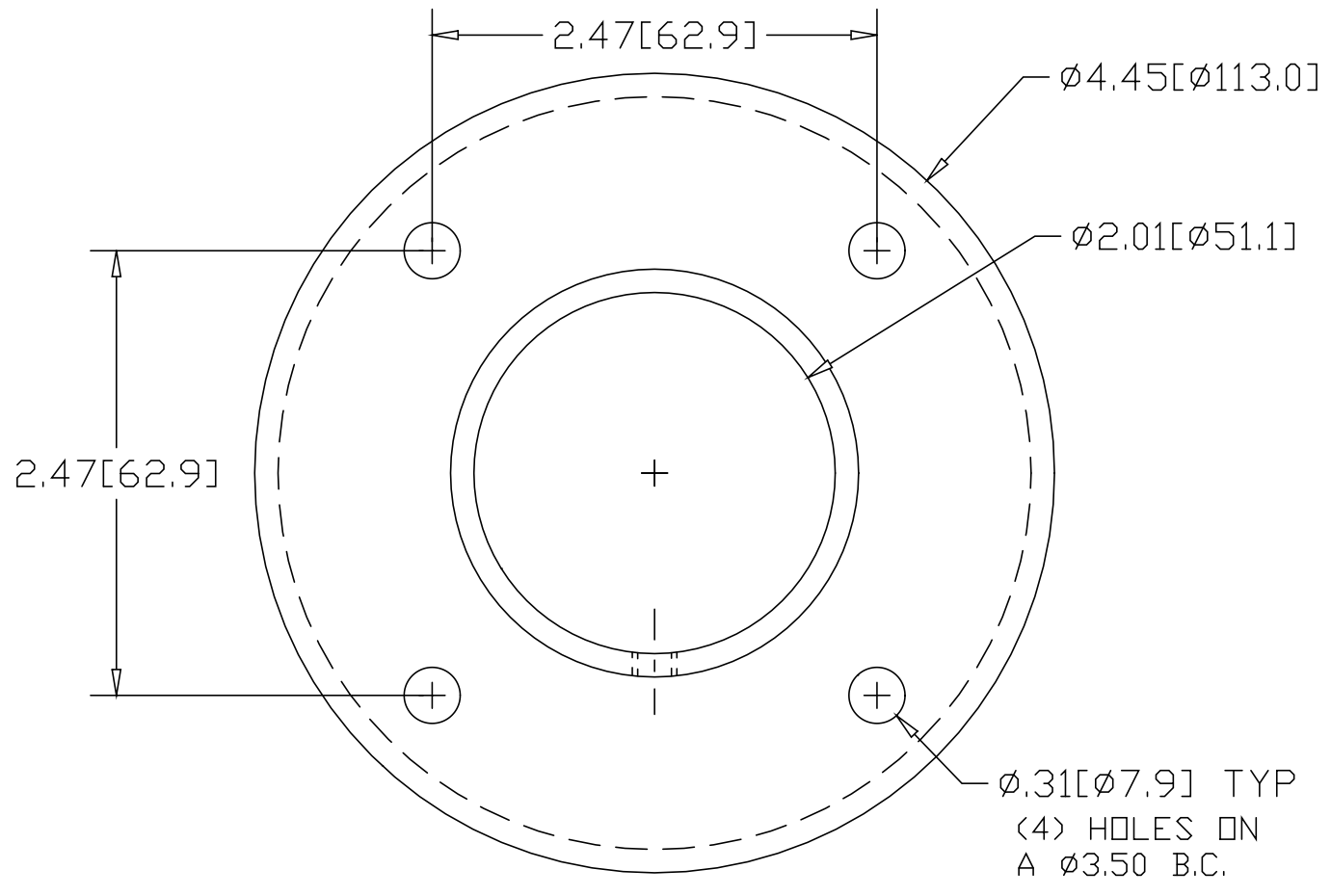

INCHES [MILLIMETERS]

ALTERNATE MATERIAL		PART NUMBER					
.125 (3003) ALUMINUM ASTM B209		1487T					
10 GA. (304) STAINLESS STEEL ASTM A240		1547T					
PART NAME 2.00" OD TUBE HEAVY BASE FLANGE W/(4) HOLES & SET-SCREW							
MATERIAL 10 GA. HRP&D STEEL ASTM A569							
DATE	9/13/94						
DRAWN BY	RJF						
FINISH	MILL						
SIZE	A	WEIGHT	.64 LBS	PART NUMBER	1447T	REV	