

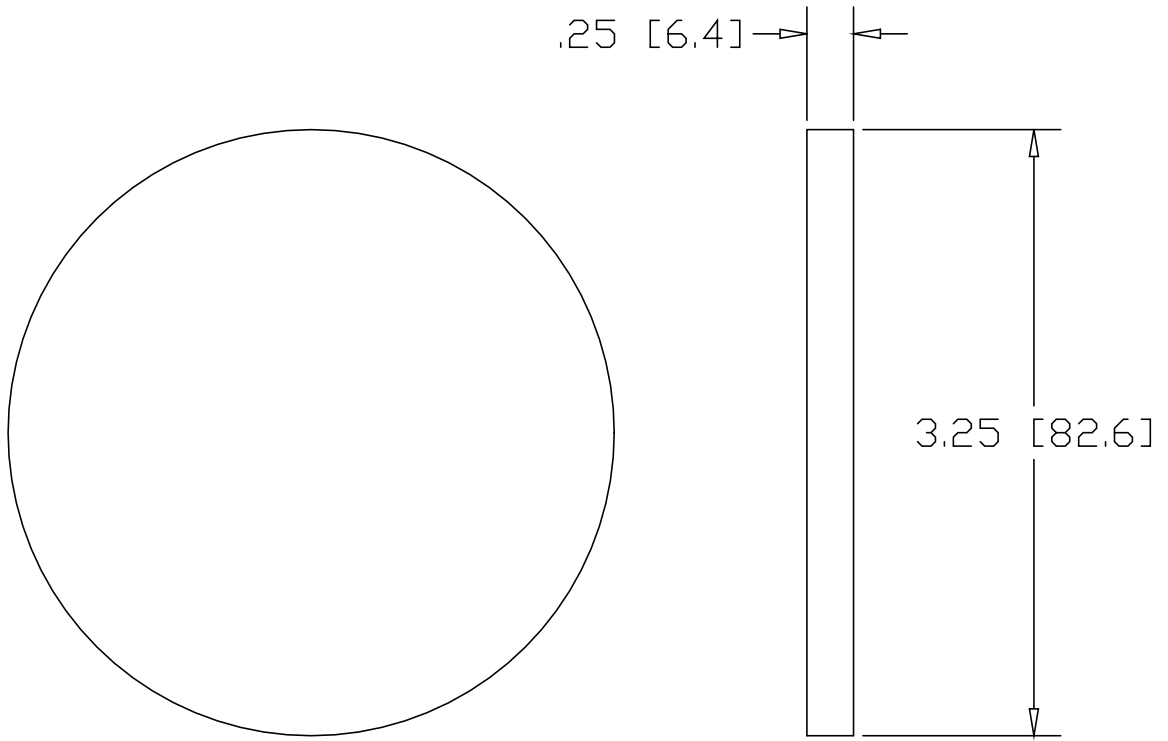

REV
SH
D158
DWG NO

REVISIONS			
REV	DESCRIPTION	DATE	APPROVED



INCHES[MILLIMETERS]

ALTERNATE MATERIAL	PART NUMBER
.250 (3003) ALUMINUM ASTM B209	D159
.250 (304) STAINLESS STEEL ASTM A240	D160
.250 (260) BRASS ASTM B19,B36	D161

PART NAME 3.25" OD TUBE SIZE TYPE-D WELD-ON DISK			
MATERIAL .250 HRP&□ STEEL ASTM A569			
DATE 11/20/98		THE WAGNER COMPANIES R & B WAGNER, INC. AND J. G. BRAUN CO.	
DRAWN BY RJF			
FINISH MILL			
SIZE A	WEIGHT .55 LBS	PART NUMBER D158	REV