

REVISIONS			
REV	DESCRIPTION	DATE	APPROVED
A	REVISED TOLERANCES	11/01/10	RJF

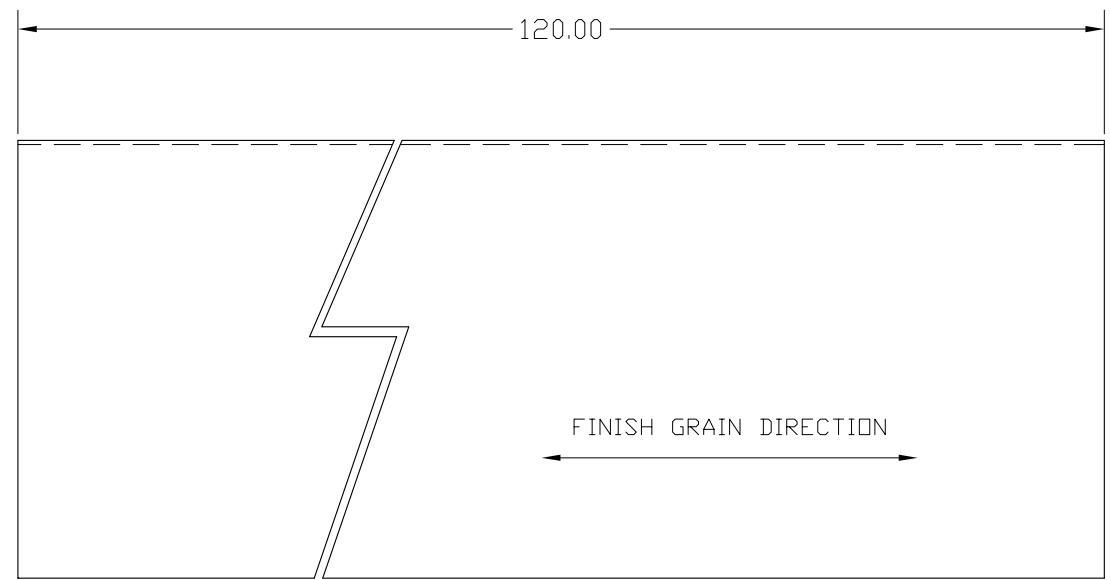
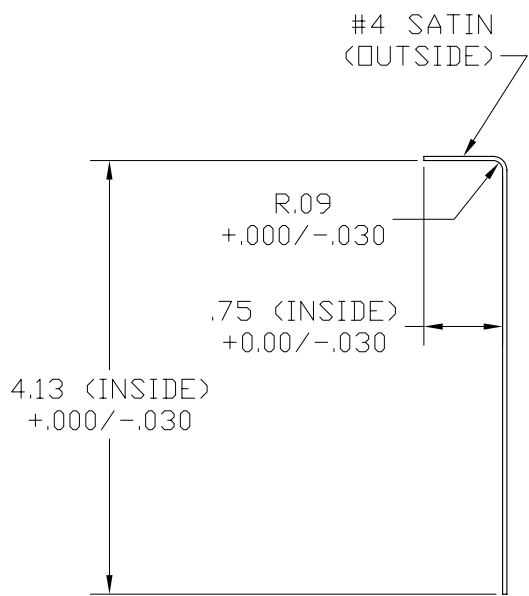

PART NAME		CLADDING, GLASS RAIL SHOE MOLDING		
MATERIAL		20 GA. 316 STAINLESS STEEL		
DATE	06/06/11	WAGNER	THE WAGNER COMPANIES R & B WAGNER, INC. AND J. G. BRAUN CO.	
DRAWN BY	RJF			
FINISH	#4 SATIN	SIZE	WEIGHT	PART NUMBER
		A	6.029 LBS	GR3806.4
				REV
				A