

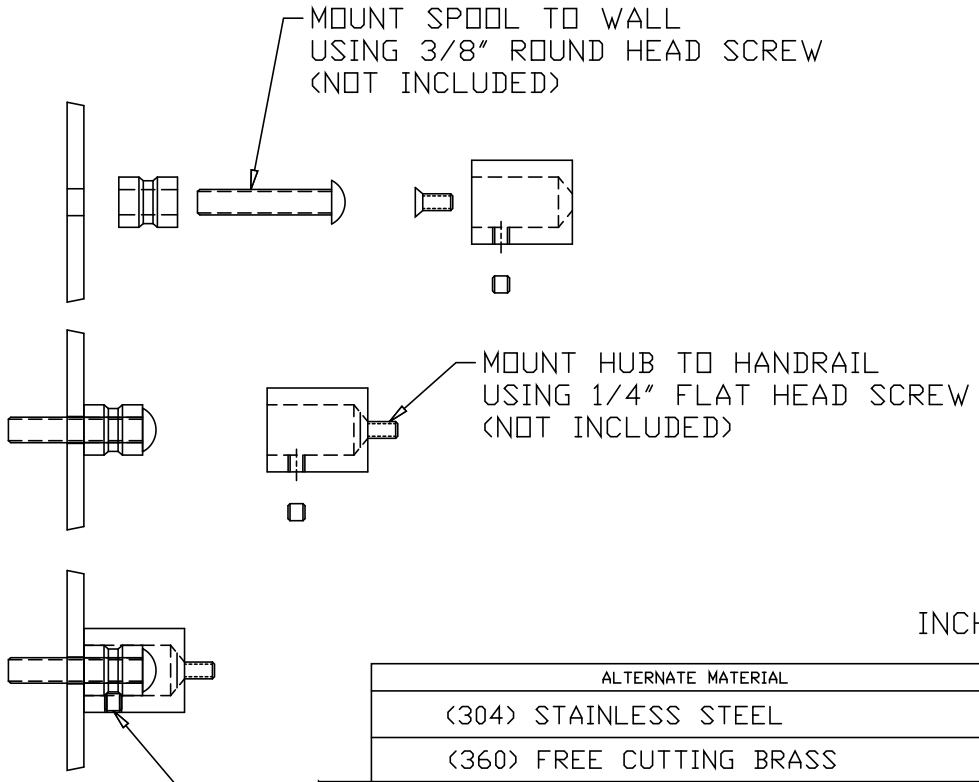

REV
SH
VA150W
DWG NO

REVISIONS			
REV	DESCRIPTION	DATE	APPROVED

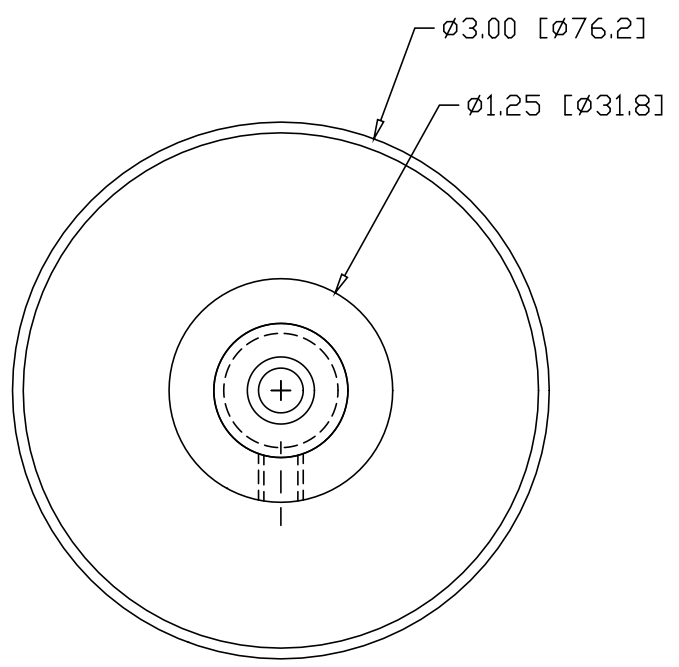
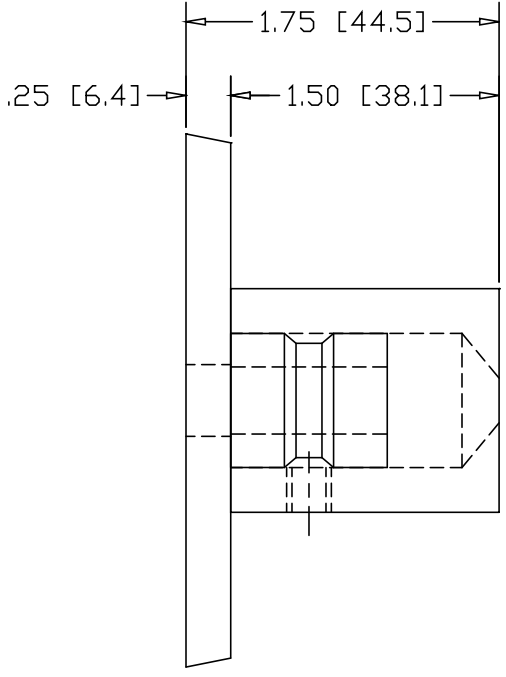

INCHES [MILLIMETERS]

ALTERNATE MATERIAL	PART NUMBER
<304> STAINLESS STEEL	VS150W
<360> FREE CUTTING BRASS	VB150W

PART NAME		HANDRAIL CONCEALED MOUNT HUB WITH BASE DISK	
MATERIAL		<6063> ALUMINUM	
DATE	9/17/03	 THE WAGNER COMPANIES R & B WAGNER, INC. AND J. G. BRAUN CO.	PART NUMBER
DRAWN BY	RJF		
FINISH	#4 SATIN		
SIZE	A	WEIGHT	VA150W
		REV	