

REV
SH
1621
DWG NO

REVISIONS			
REV	DESCRIPTION	DATE	APPROVED

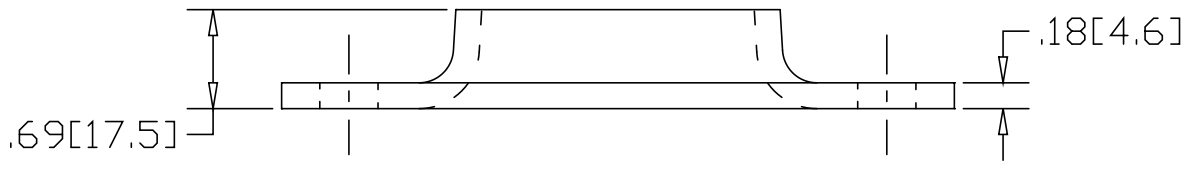
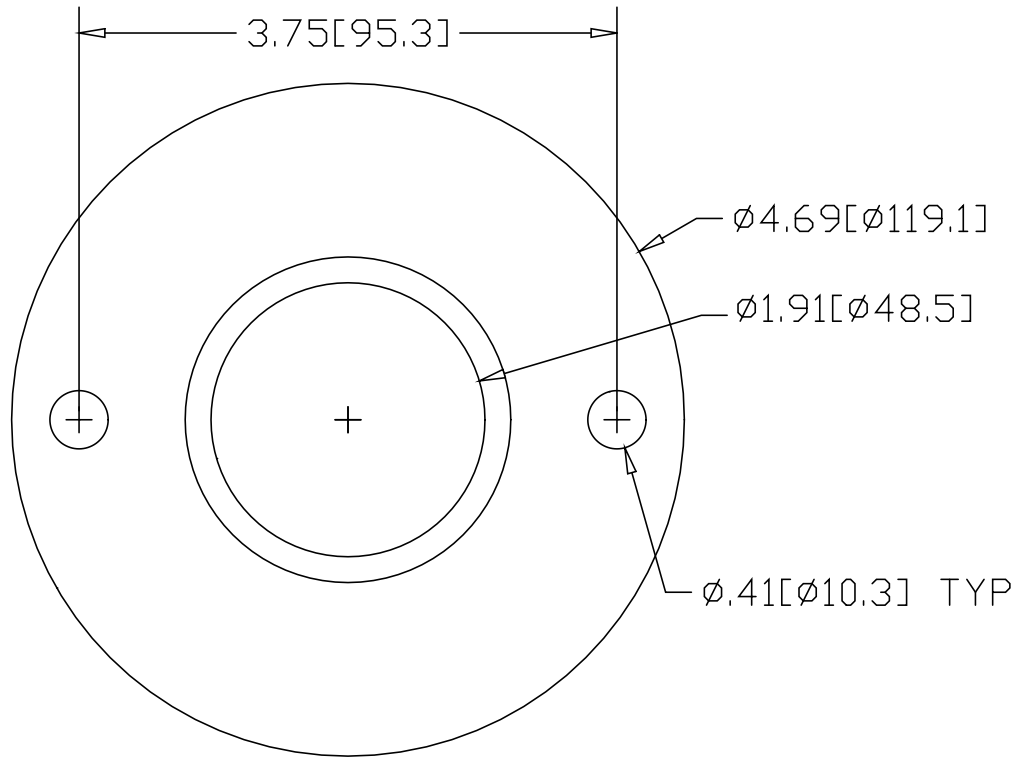

INCHES [MILLIMETERS]

*USE WITH ANCHOR PLATE
#B1628 IN STEEL
#B1648 IN ALUMINUM

ALTERNATE MATERIAL	PART NUMBER
.190 (3003) ALUMINUM ASTM B-209	1641

PART NAME 1-1/2" PIPE SIZE EXTRA HEAVY FLANGE W/(2) HOLES			
MATERIAL 7 GA. HPR&D STEEL ASTM A-569			
DATE 3/2/95		R & B WAGNER, INC.	
DRAWN BY RJF		FINISH MILL	SIZE A
		PART NUMBER 1621	REV