

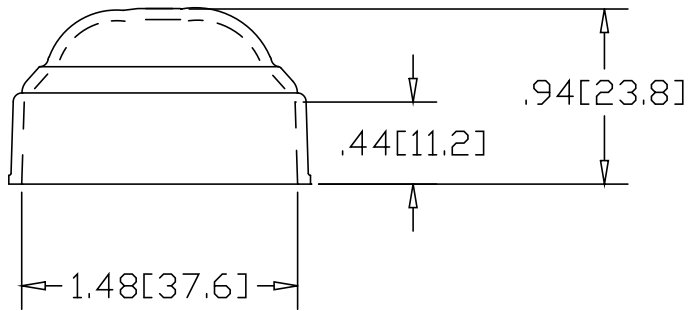

REV
SH
DWG NO 5156

REVISIONS			
REV	DESCRIPTION	DATE	APPROVED

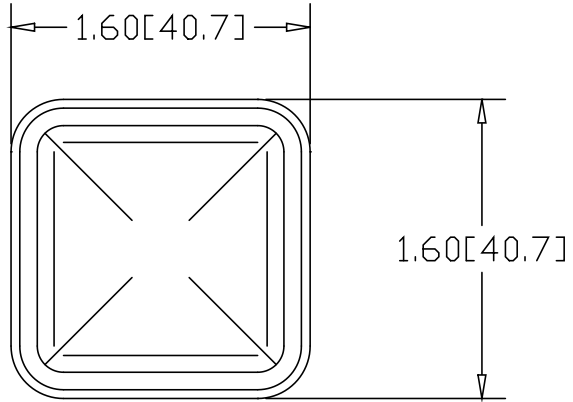

INCHES [MILLIMETERS]

ALTERNATE MATERIAL	PART NUMBER
.050 (3003) ALUMINUM ASTM B209	5158
18 GA. 304 STAINLESS STEEL	5160

PART NAME		1.50" SQUARE NEWEL POST CAP					
MATERIAL		18 GA. CR STEEL ASTM A366					
DATE	11/8/96	 THE WAGNER COMPANIES R & B WAGNER, INC. AND J. G. BRAUN CO.					
DRAWN BY	RJF						
FINISH	MILL						
SIZE	A	WEIGHT	.09 lbs	PART NUMBER	5156	REV	