

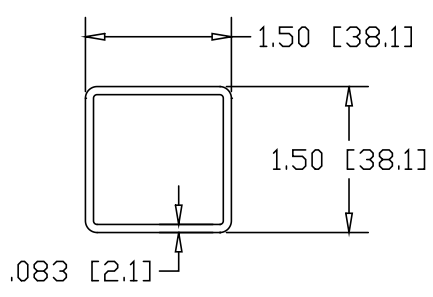

REV
SH
6373
DWG NO

REVISIONS			
REV	DESCRIPTION	DATE	APPROVED

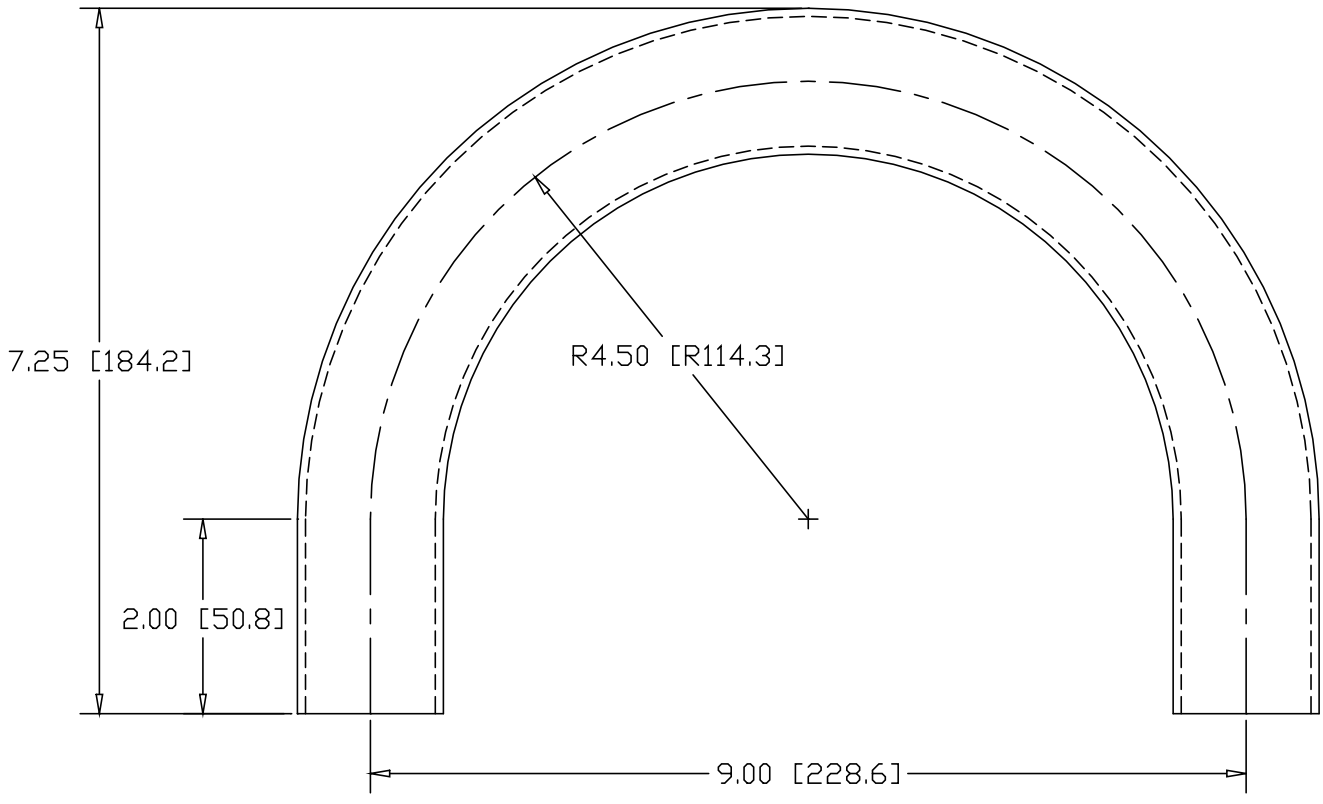

INCHES [MILLIMETERS]

PART NAME 1.50" SQUARE STEEL 180° X 4.50" CLR ELL W/(2) 2" TANGENTS			
MATERIAL 1.50" X .083W SQUARE STEEL TUBE			
DATE 10/3/00		THE WAGNER COMPANIES R & B WAGNER, INC. AND J. G. BRAUN CO.	
DRAWN BY RJF			
FINISH MILL	SIZE A	WEIGHT 2.42 LBS	PART NUMBER 6373
			REV