

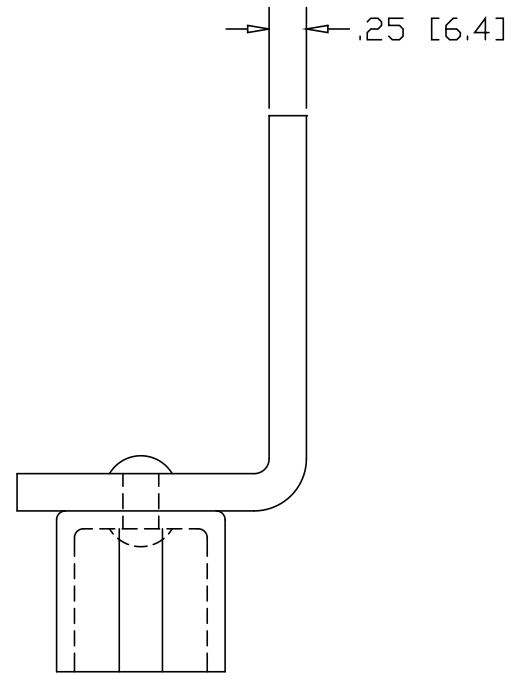

REV
SH
5019NH
DWG NO

REVISIONS			
REV	DESCRIPTION	DATE	APPROVED

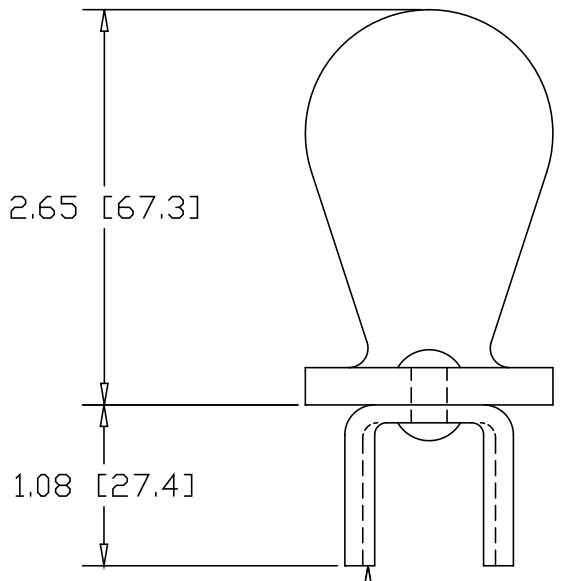
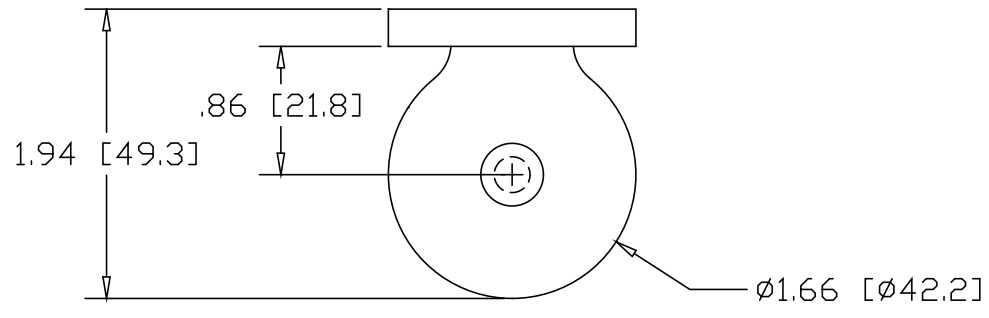

DRIVE-ON YOKE SIZED TO FIT
INSIDE 1-1/4" SCH 40 PIPE

PART NAME		1-1/4" DRIVE-ON POST BRACKET, NO HOLE					
MATERIAL		.250 HRP&O STEEL ASTM A569					
DATE	9/12/03		THE WAGNER COMPANIES R & B WAGNER, INC. AND J. G. BRAUN CO.				
DRAWN BY	RJF						
FINISH	MILL						
SIZE	A	WEIGHT	.44 LBS	PART NUMBER	5019NH	REV	