

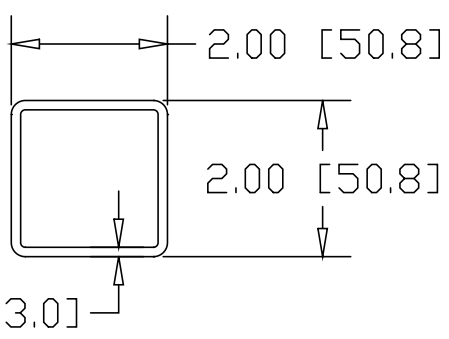

REV
SH
DWG NO 6388

REVISIONS			
REV	DESCRIPTION	DATE	APPROVED

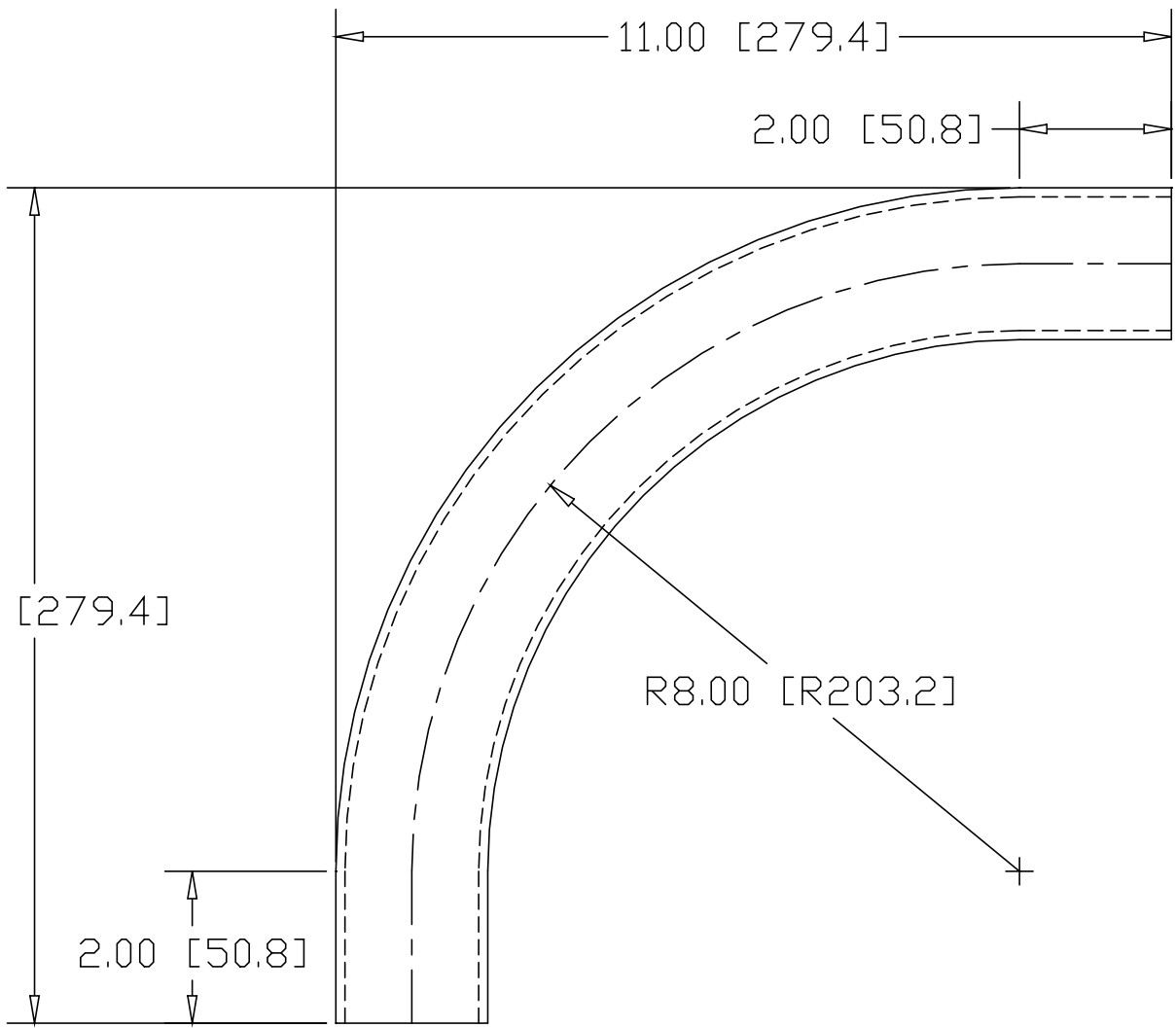

INCHES [MILLIMETERS]

PART NAME		2.00" SQUARE STEEL 90° X 8.00"CLR ELL W/⟨2⟩ 2" TANGENTS					
MATERIAL		2.00" X .120W SQUARE STEEL TUBE					
DATE	10/3/00		THE WAGNER COMPANIES R & B WAGNER, INC. AND J. G. BRAUN CO.				
DRAWN BY	RJF						
FINISH	MILL						
SIZE	A	WEIGHT	4.06 LBS	PART NUMBER	6388	REV	