

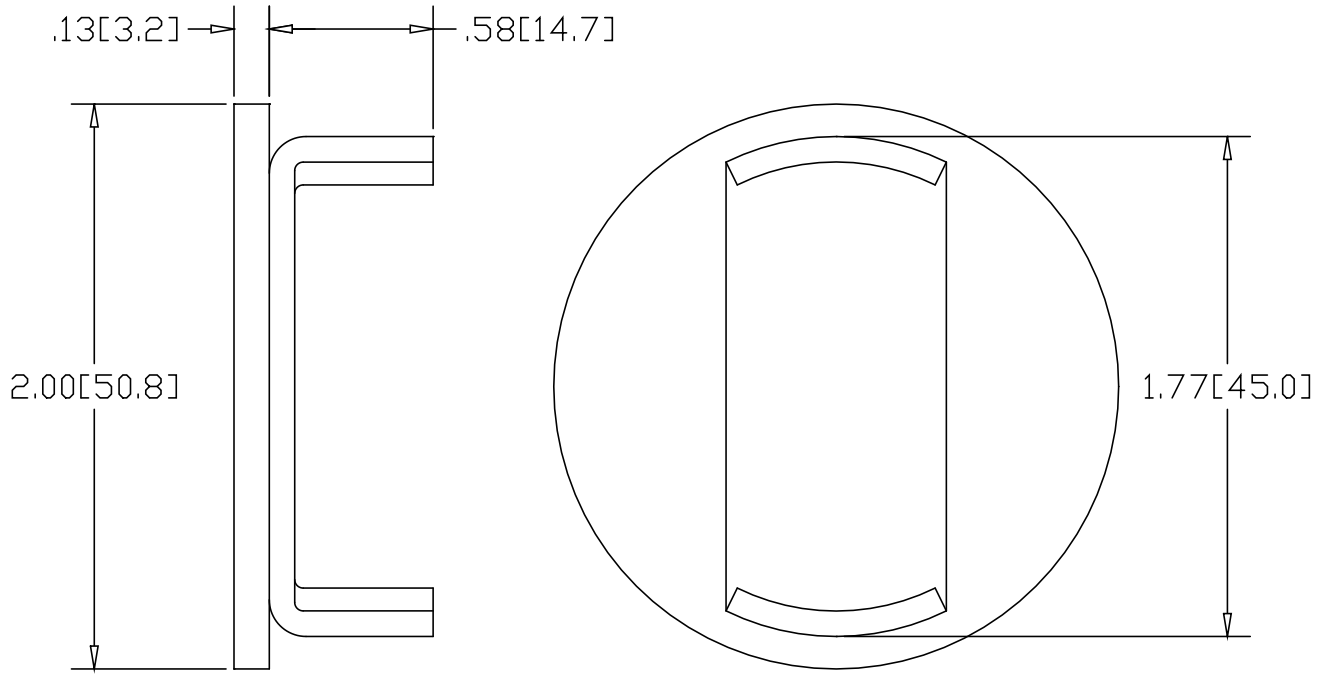

REV  
SH  
DWG NO D090E

REVISIONS			
REV	DESCRIPTION	DATE	APPROVED



INCHES [MILLIMETERS]

ALTERNATE MATERIAL	PART NUMBER
.125 (3003) ALUMINUM ASTM B209	D091E
10 GA. (304) STAINLESS STEEL ASTM A240	D092E

PART NAME		2" O.D. X .120W TUBE TYPE "E" DRIVE-ON DISK	
MATERIAL		10 GA. HRP&O STEEL ASTM A569	
DATE	6/13/96	 <b>THE WAGNER COMPANIES</b> R & B WAGNER, INC. AND J. G. BRAUN CO.	
DRAWN BY	RJF		
FINISH	MILL		
SIZE	WEIGHT	PART NUMBER	REV
A	.16 LBS	D090E	