

REV  
SH  
1415T  
DWG NO

REVISIONS			
REV	DESCRIPTION	DATE	APPROVED

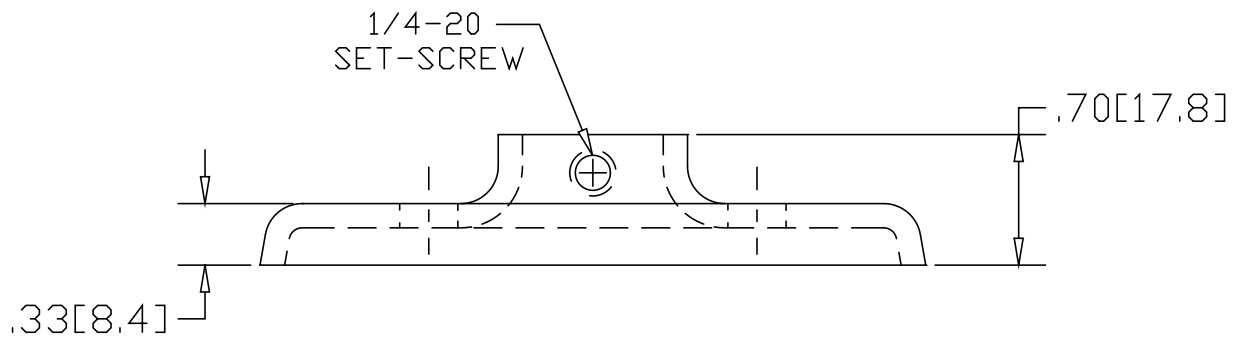
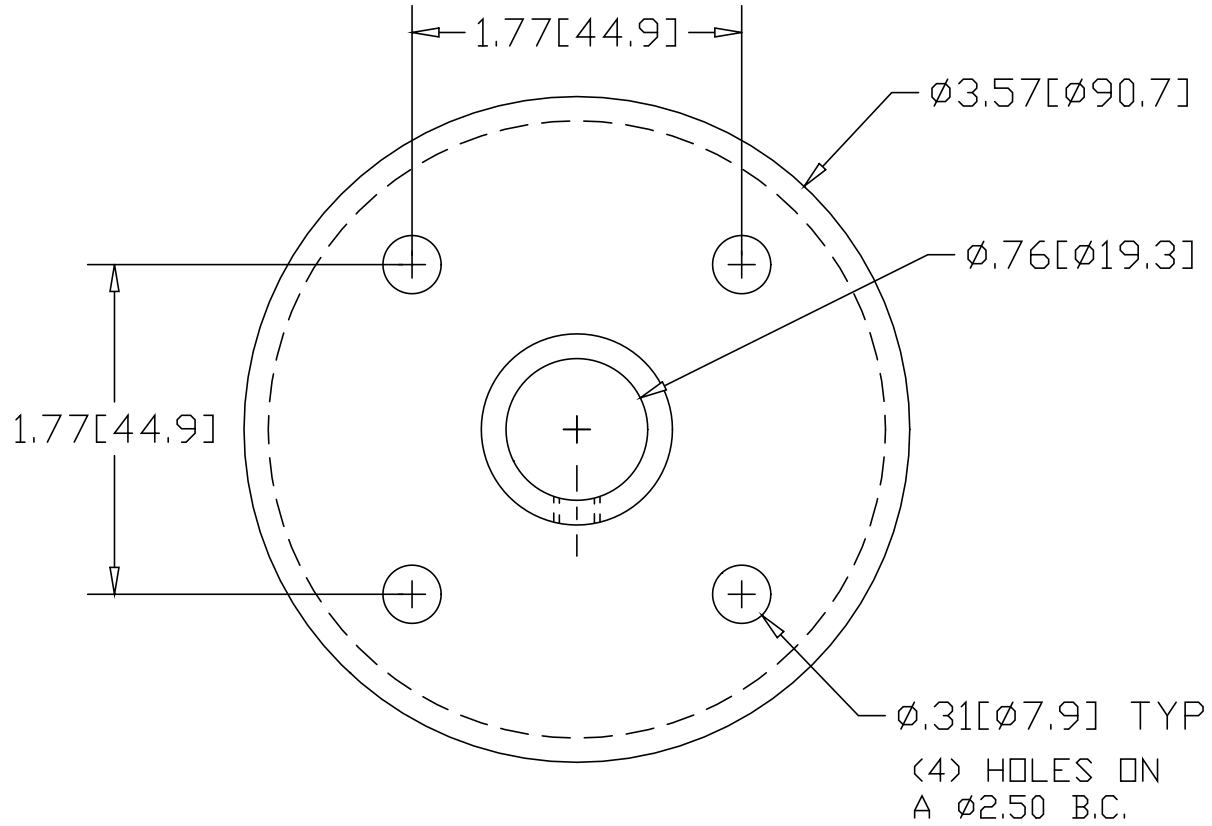

INCHES [MILLIMETERS]

ALTERNATE MATERIAL	PART NUMBER
.125 (3003) ALUMINUM ASTM B209	1455T
10 GA. (304) STAINLESS STEEL ASTM A240	1515T

PART NAME .75" OD TUBE HEAVY BASE FLANGE W/(4) HOLES & SET-SCREW				
MATERIAL 10 GA. HRP&D STEEL ASTM A569				
DATE 9/13/94				
DRAWN BY RJF				
FINISH MILL	SIZE A	WEIGHT .41 LBS	PART NUMBER 1415T	REV