

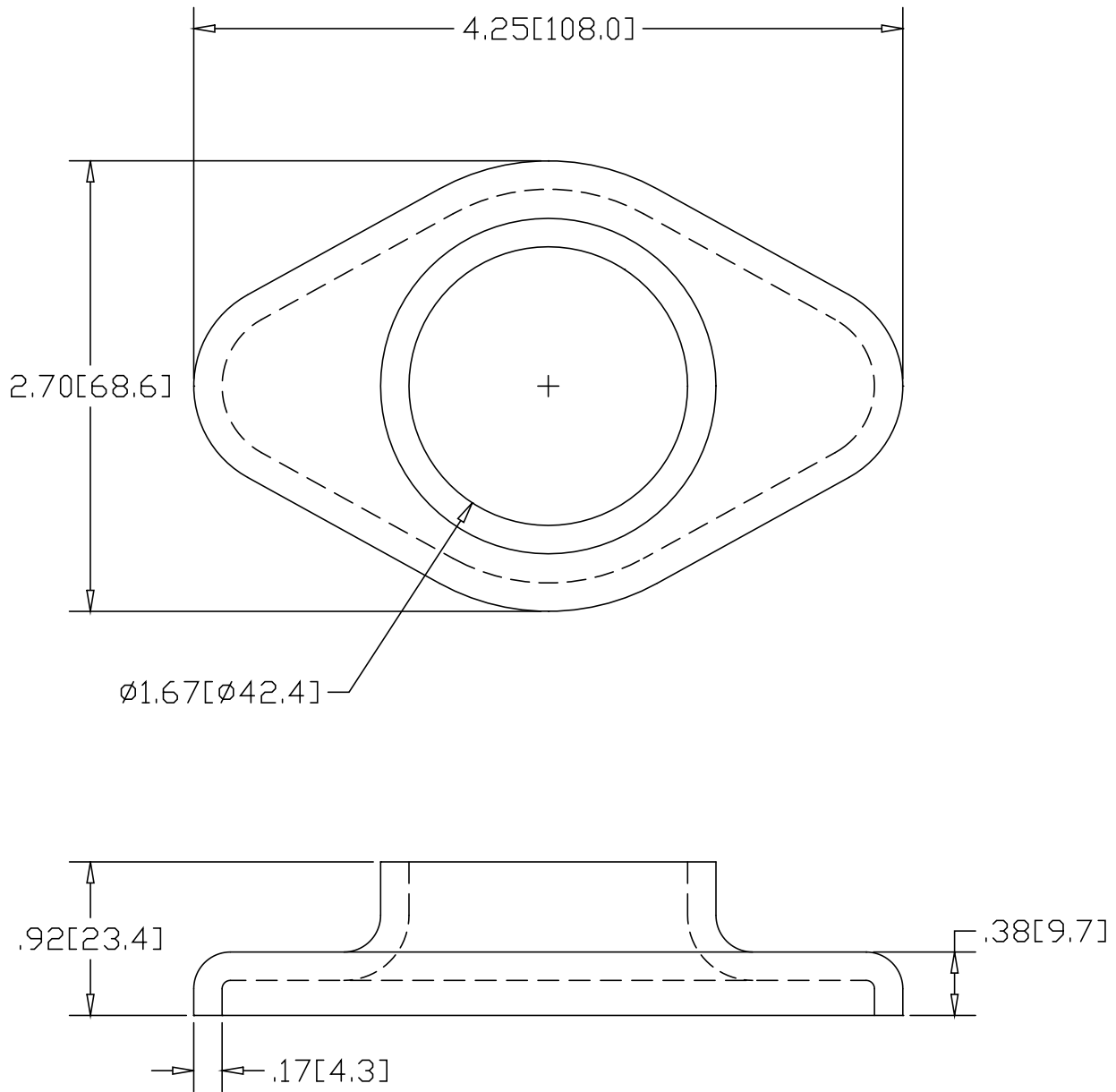

REV  
SH  
4910  
DWG NO

REVISIONS			
REV	DESCRIPTION	DATE	APPROVED



INCHES [MILLIMETERS]

ALTERNATE MATERIAL	PART NUMBER
.190 (3003) ALUMINUM ASTM B209	4940
7 GA. (304) STAINLESS STEEL ASTM A240	4970

PART NAME 1-1/4" PIPE SIZE TAPERED HEAVY BASE FLANGE			
MATERIAL 7 GA. HRP&O STEEL ASTM A569			
DATE 5/22/95		R & B WAGNER, INC.	
DRAWN BY RJF			
FINISH MILL	SIZE A	WEIGHT .41 LBS	PART NUMBER 4910
			REV