

2

1

B

B

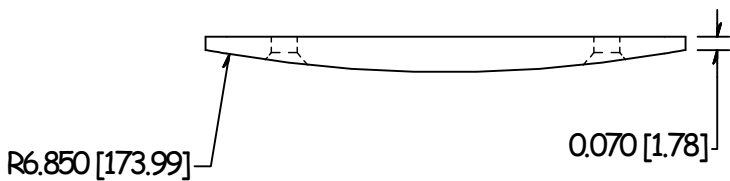

A

A

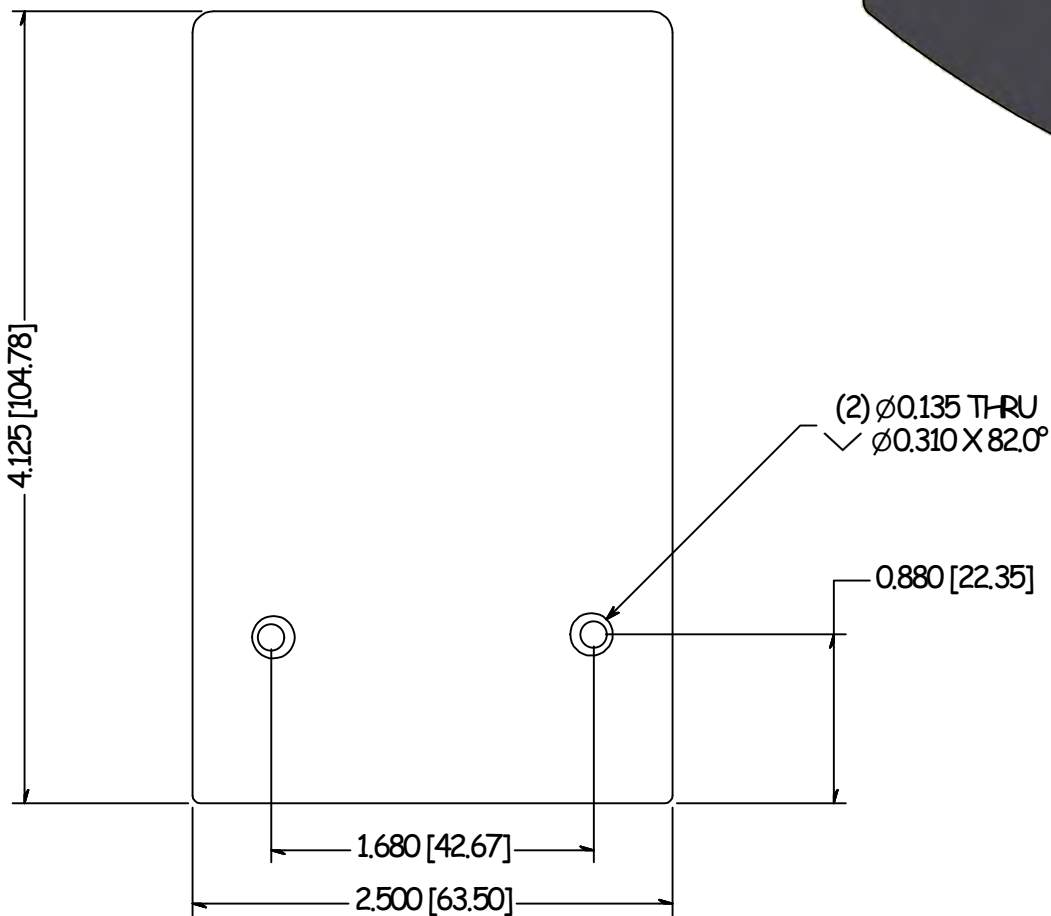

TOLERANCE		CUT LENGTH:	FINISH:	DESCRIPTION: END CAP, SHOE MOLDING			
FRACTION: X/XX..... = ± 1/16" over 4ft.		DEVELOPED LENGTH:	MILL	MATERIAL:	MATERIAL DESC:		
DECIMAL: X.XX..... = ± .030 X.XXX..... = ± .010			N/A	Aluminum 6063-T52	6063-T52		
UNLESS OTHERWISE NOTED		TOOL NUMBER:	SIZE:	DATE:		THE WAGNER COMPANIES	
	A		A	3/30/2011		R & B WAGNER, INC. AND J. G. BRAUN CO.	
				DRAWN BY:		SHEET:	PART NUMBER:
				kturdo		1 OF 1	GR2452EMH
				ITEM NUMBER:		REV:	
				GR2452EMH		1	1

2

1

