

2

1

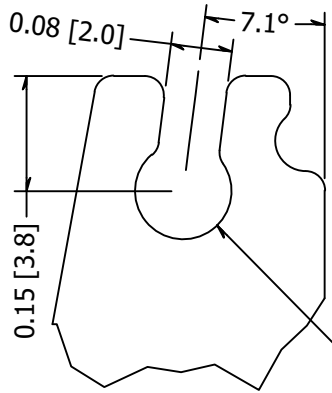

DART MATING FEATURE
EXTRUDED ALUMINUM

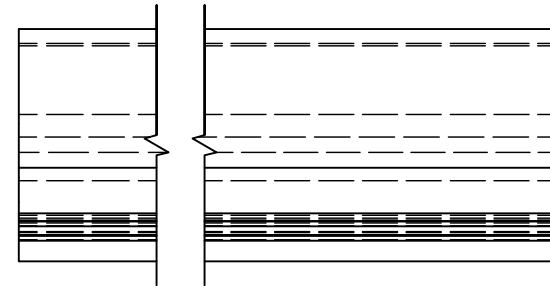
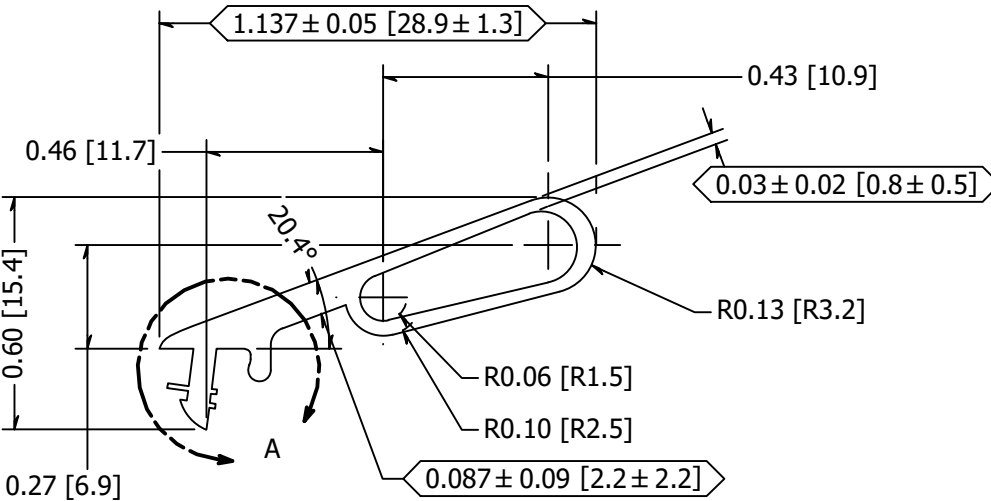
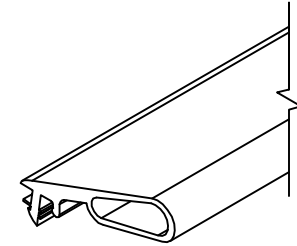
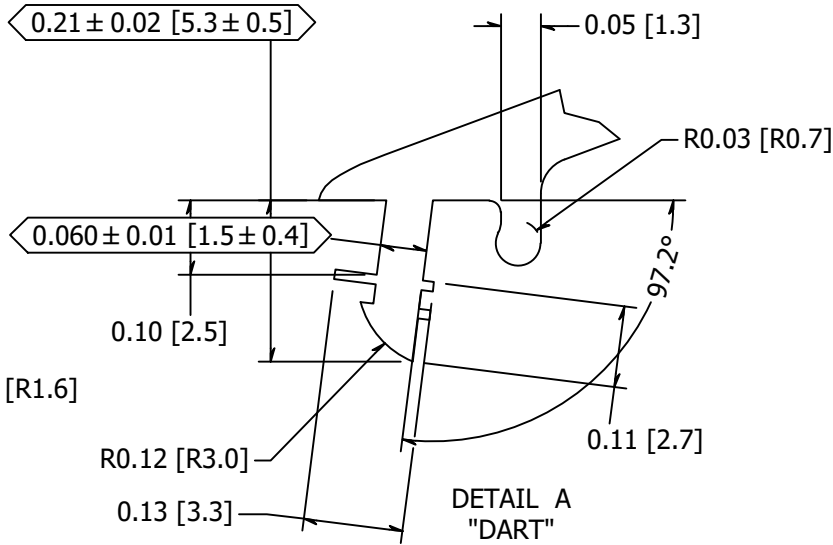

REVISION HISTORY

REV	DESCRIPTION	DATE	APPROVED
1	REDESIGN OF SHAPE AND LENGTH. INCORPORATION OF CRITICAL DIMENSIONS	5/18/2023	WEP

TOLERANCE X.XX +/- 0.01 X.XXX +/- 0.005 Angle +/- 0.5 Unless Otherwise Specified	CUT LENGTH:	FINISH:	DESCRIPTION:
	-	MILL	GASKET, RUBBER, LEVEL LOCK +, GASKET W/O CLADDING, 1.125" X 0.60", BLACK
	DEVELOPED LENGTH:	WEIGHT:	MATERIAL:
	-	N/A	z-Rubber
TOOL NUMBER:		DATE:	MATERIAL DESC:
-		6/5/2023	70D DENSE EPDM RUBBER
		DRAWN BY:	REV:
		A. Seeboth	1
		PART NUMBER:	
		GR9LL1056	

Part Number	Cut Length
GR9LL1056-25	25FT
GR9LL1056-50	50FT
GR9LL1056	250FT

WAGNER™
 COLLABORATIVE METALWORKS <http://www.wagnercompanies.com/>
 10600 W Brown Deer Rd
 Milwaukee, WI 53224

2

1