

- NOTES:
1. DIMENSIONS SHOWN AS INCHES [MILLIMETERS].
 2. DIMENSIONS WITH (XXX) DENOTE AS REFERENCE.
 3. ENCIRCLED DIMENSIONS DENOTE AS CRITICAL DIMENSIONS.
 4. BURRS 0.015 MAX. [0.381]

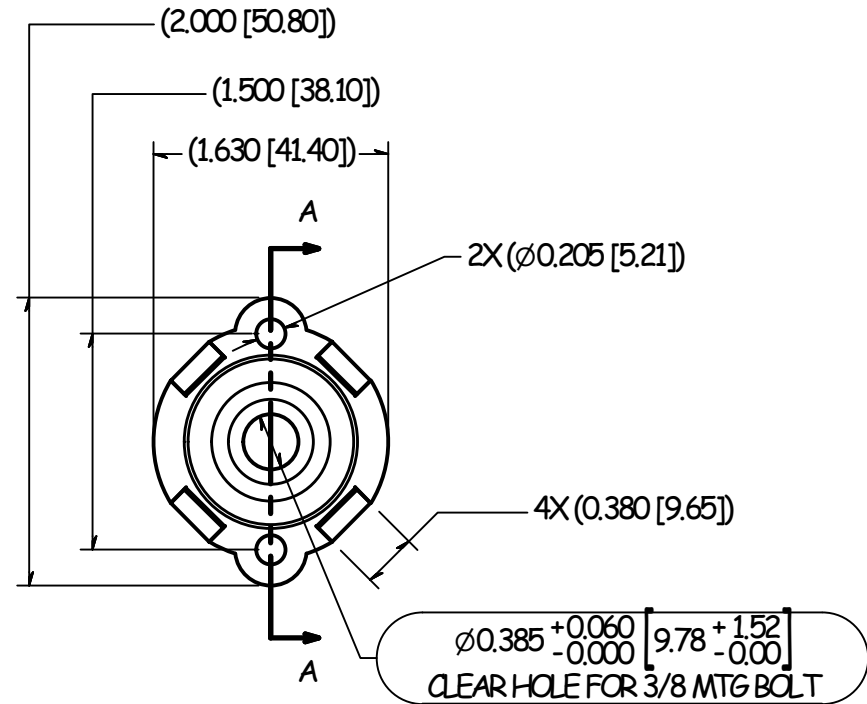
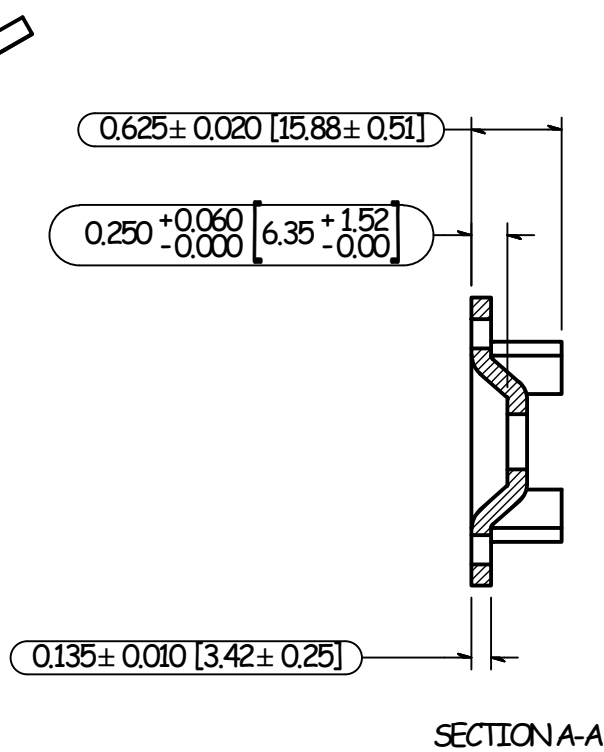

REVISION HISTORY			
REV	DESCRIPTION	DATE	APPROVED
1	Revise .26 to .205	10/31/2017	TLK

DESCRIPTION: BRACKET FILLER ST STYLE F 1HOLE .625	
MATERIAL: S330	MATERIAL DESC: SHEET STEEL 13 GA HRPO 48 x 120 ASTM A1011
DATE: 1/14/2010	REV: 1
DRAWN BY: R. Knepprath	
PART NUMBER: 3545B	

TOLERANCE	CUT LENGTH:	FINISH:
UNLESS OTHERWISE NOTED, TOLERANCES TO CONFORM TO ES.03.011		MILL
	DEVELOPED LENGTH:	WEIGHT:
	TL0531, TL8534, TL8533	0.12 lbmass

