

REV
SH
8055
DWG NO

REVISIONS			
REV	DESCRIPTION	DATE	APPROVED

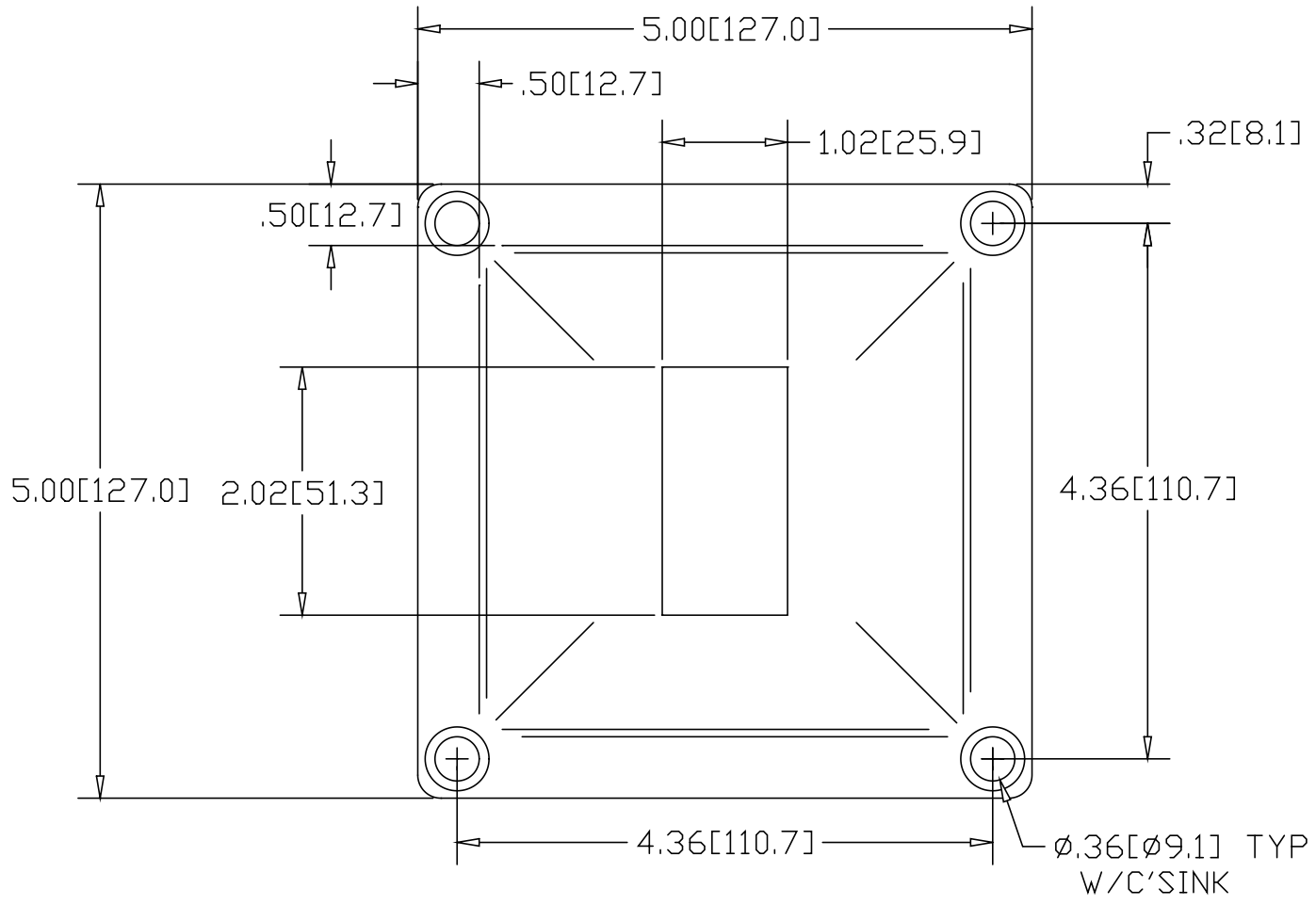

*USE WITH ANCHOR PLATE
#8043 IN STEEL
#8044 IN ALUMINUM

INCHES [MILLIMETERS]

ALTERNATE MATERIAL	PART NUMBER
.190 (3003) ALUMINUM ASTM B209	8056

PART NAME 2" X 1" RECTANGULAR TUBE FLANGE			
MATERIAL 7 GA. HRP&D STEEL ASTM A569			
DATE 6/12/96		R & B WAGNER, INC.	
DRAWN BY RJF		FINISH MILL	SIZE A
		PART NUMBER 8055	REV