

REV

SH

1103-3

DWG NO

REVISIONS

REV	DESCRIPTION	DATE	APPROVED
-----	-------------	------	----------

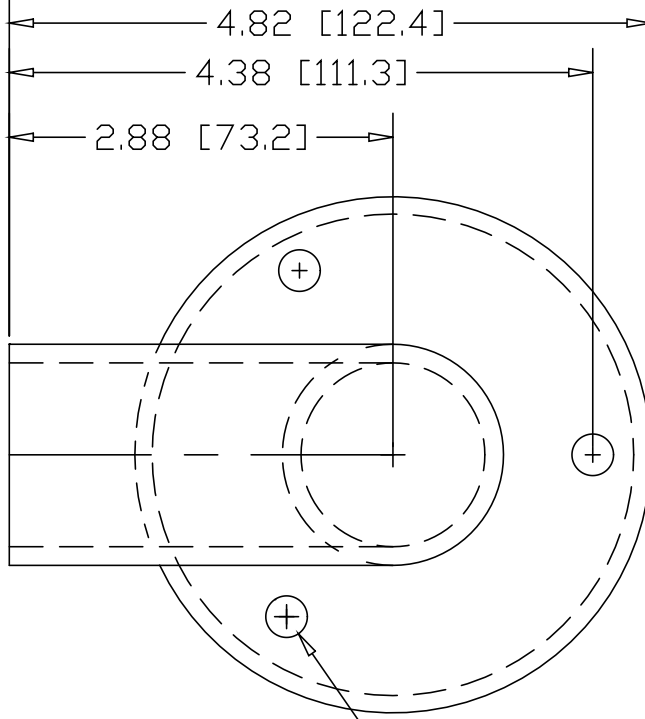

$\phi .31$  [ $\phi 7.9$ ]  
(3) ON 3.00 B.C.

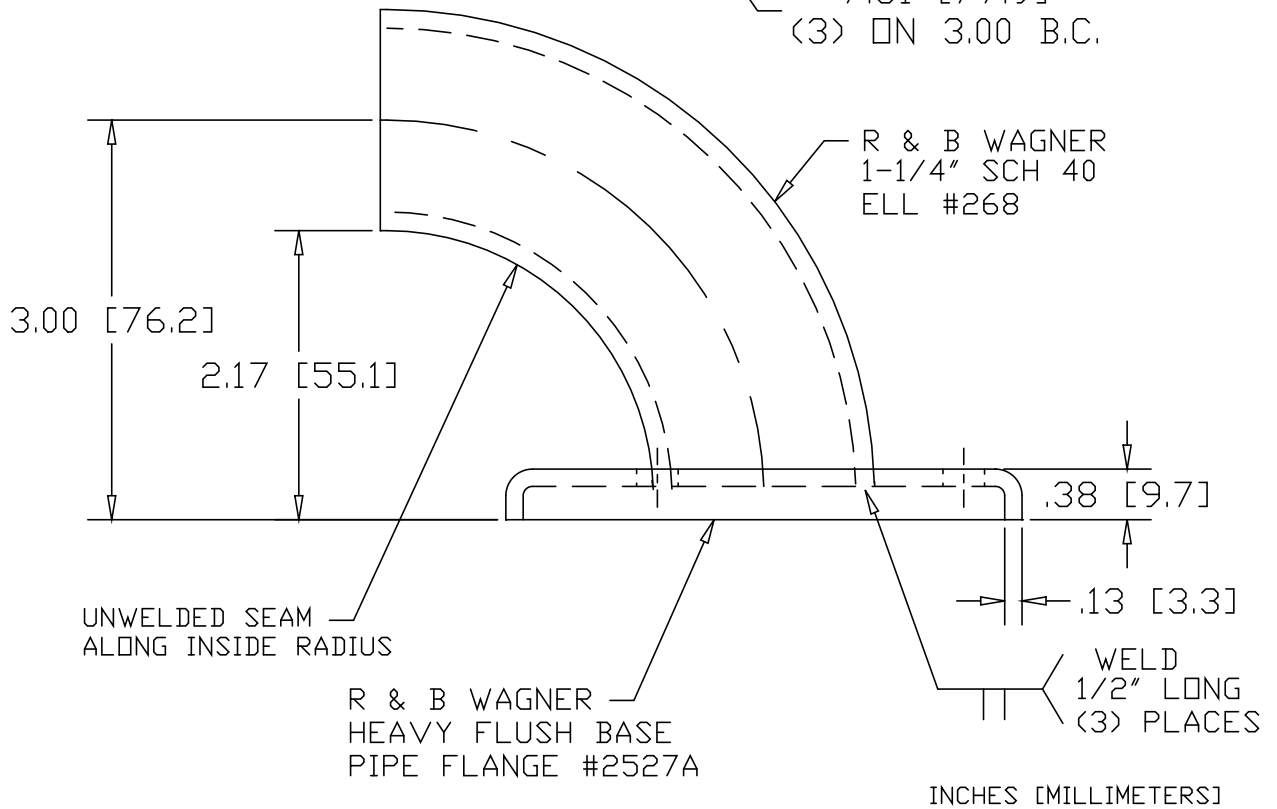

PART NAME		1-1/4" PIPE SIZE X 3.00CL WALL RETURN W/3 HOLES		
MATERIAL		STEEL - ASTM A569		
DATE	8/07/02		<b>THE WAGNER COMPANIES</b> R & B WAGNER, INC. AND J. G. BRAUN CO.	
DRAWN BY	JAH			
FINISH	MILL			
SIZE	A	WEIGHT	PART NUMBER	1103-3
			REV	