

REV
SH
DWG NO 6957-5

REVISIONS			
REV	DESCRIPTION	DATE	APPROVED

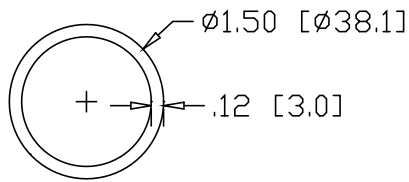
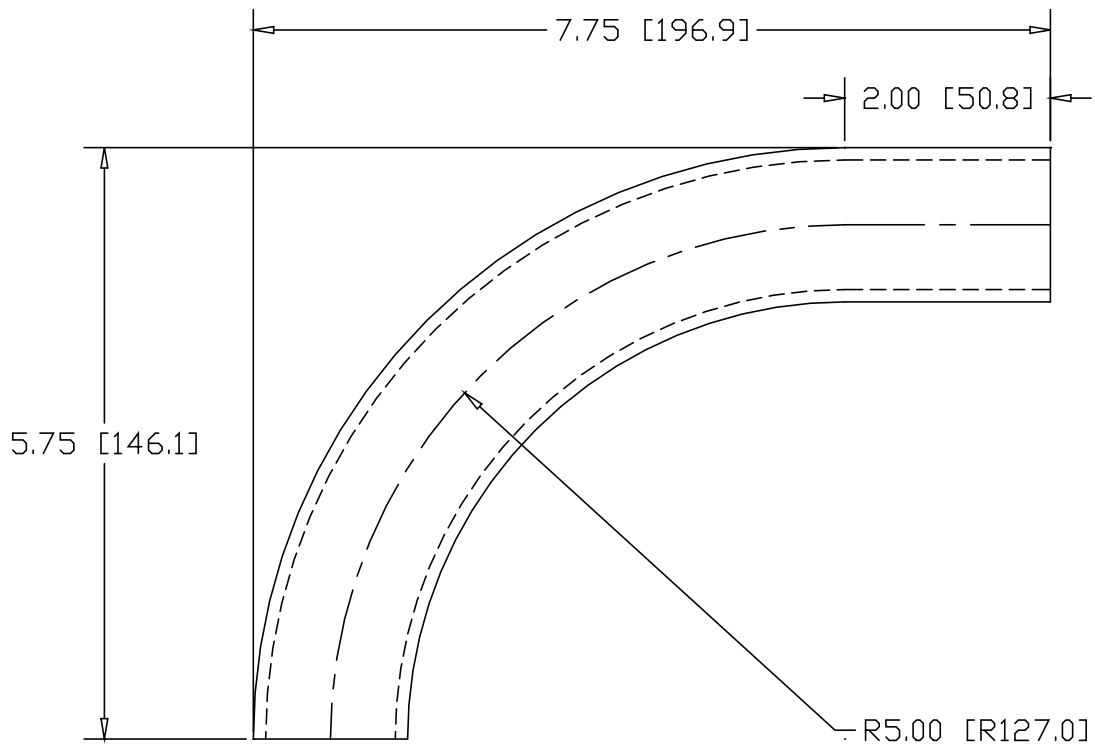

INCHES [MILLIMETERS]

ALTERNATE MATERIAL	PART NUMBER
1.50" O.D. X .125W (6061-T1) ALUMINUM TUBE	6968-5
1.50" O.D. X .120W (304) STAINLESS STEEL TUBE	6976-5

PART NAME		1.50" O.D. TUBE 90° ELL X 5.00" CLR W/(1) 2" TANGENT				
MATERIAL		1.50" O.D. X .120W STEEL TUBE				
DATE	9/22/00					
DRAWN BY	RJF					
FINISH	MILL					
SIZE	A	WEIGHT	1.46 LBS	PART NUMBER	6957-5	REV