

REV
SH
9463B
DWG NO

REVISIONS			
REV	DESCRIPTION	DATE	APPROVED

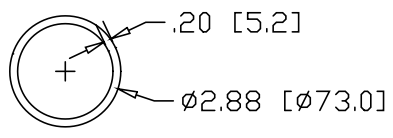
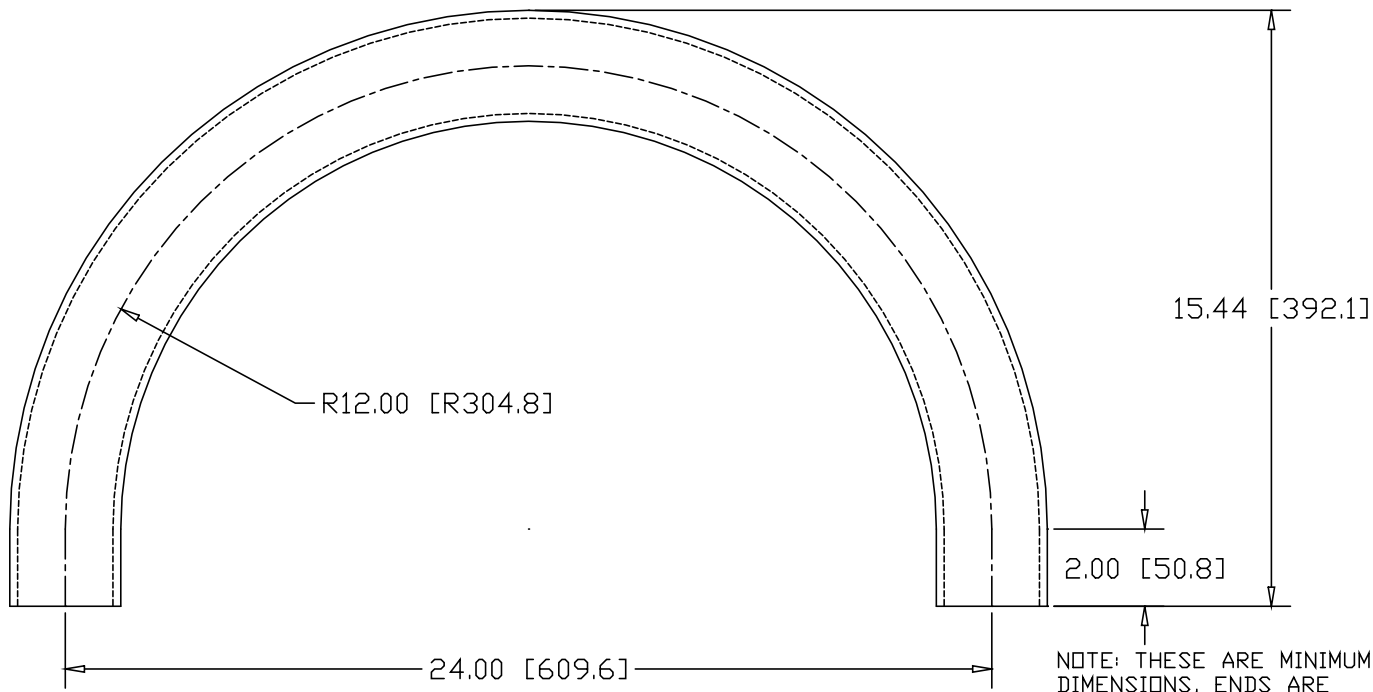

INCHES [MILLIMETERS]

ALTERNATE MATERIAL	PART NUMBER
2-1/2" SCH 40 (6063) ALUMINUM PIPE	9477B
2-1/2" SCH 40 (304) STAINLESS STEEL PIPE	9491B

PART NAME 2-1/2" PIPE SIZE 180° ELL X 10.56" I.R. W/ (2) 2" TANGENTS			
MATERIAL 2-1/2" SCH 40 A53 STEEL PIPE			
DATE 8/21/01	WAGNER	R & B WAGNER, INC.	
DRAWN BY JAH			
FINISH MILL			
SIZE A	WEIGHT 19.92 LBS	PART NUMBER 9463B	REV