

REV
SH
340
DWG NO

REVISIONS			
REV	DESCRIPTION	DATE	APPROVED

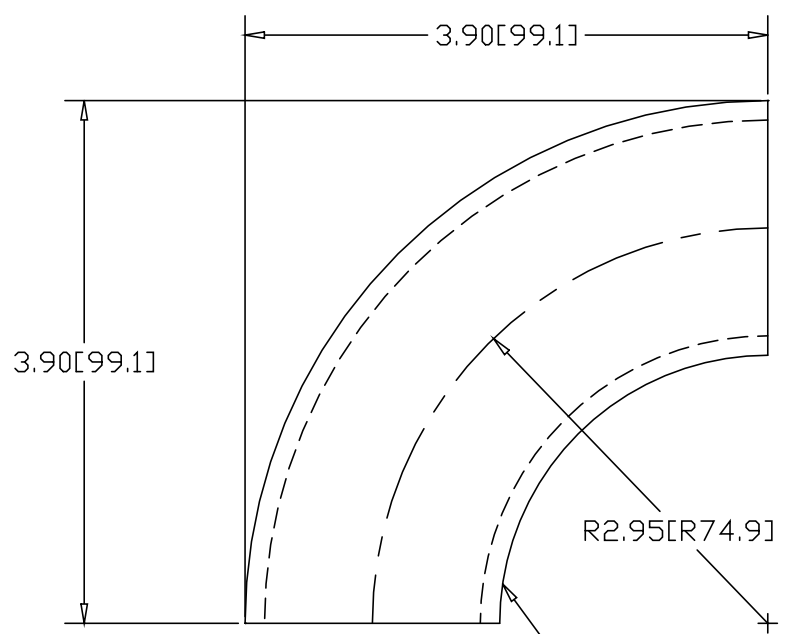

NOTE: UNWELDED SEAM
ALONG INSIDE RADIUS
(STEEL ELLS ONLY)

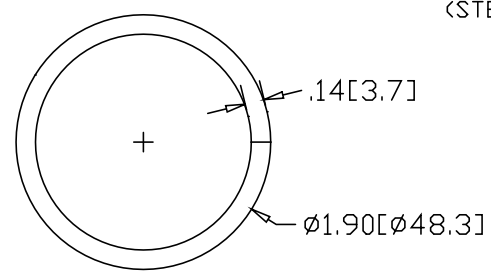

INCHES [MILLIMETERS]

ALTERNATE MATERIAL	PART NUMBER
1-1/2" SCH 40 (6063) ALUMINUM PIPE	364
1-1/2" SCH 40 (304) STAINLESS STEEL PIPE	389

PART NAME					1-1/2" PIPE SIZE 90° ELL X 2" I.R.				
MATERIAL					10 GA. HRP&D STEEL ASTM A569				
DATE		8/24/95				R & B WAGNER, INC.			
DRAWN BY		RJF							
FINISH		MILL							
SIZE	WEIGHT	PART NUMBER		REV					
A	.96 LBS	340							