

REV
SH
635AT
DWG NO

REVISIONS			
REV	DESCRIPTION	DATE	APPROVED

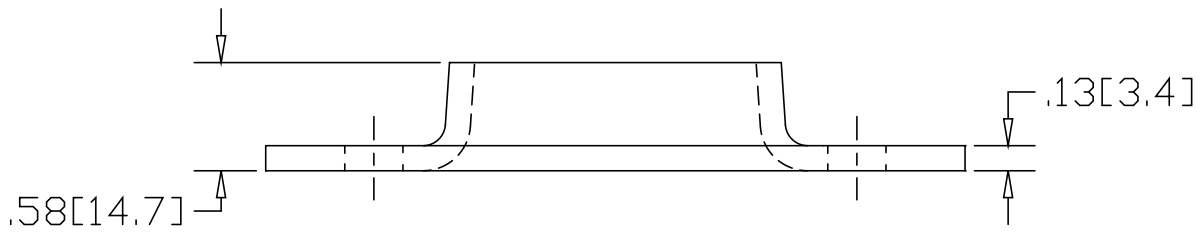
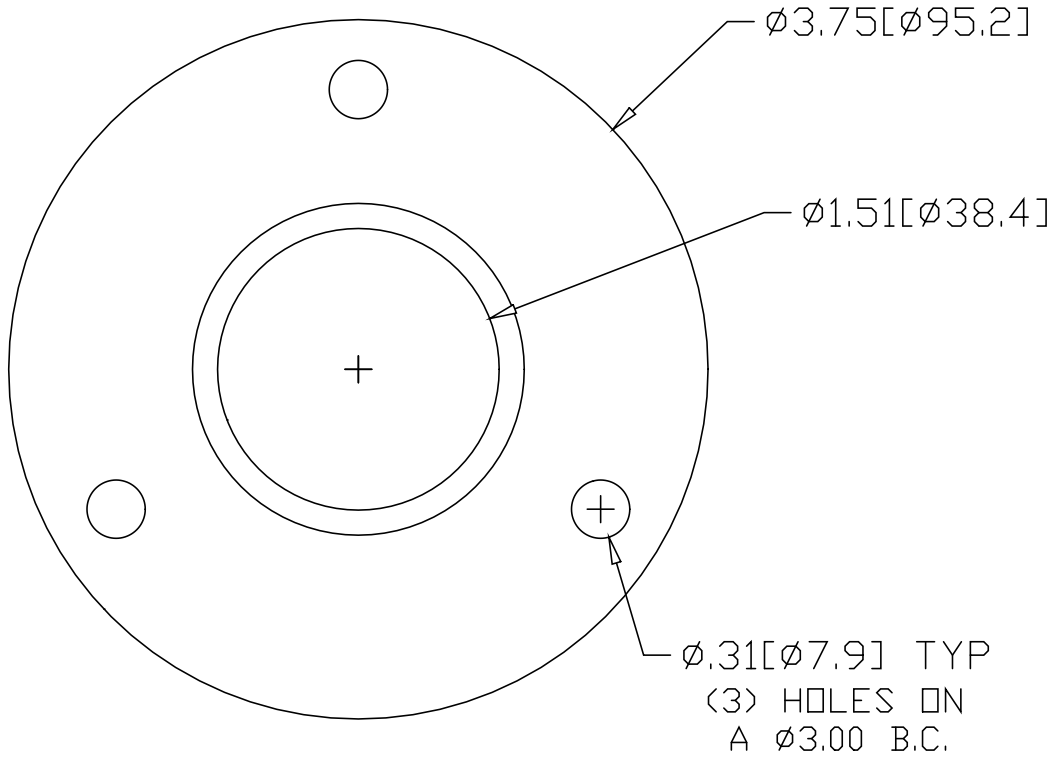

INCHES [MILLIMETERS]

ALTERNATE MATERIAL	PART NUMBER
.125 (3003) ALUMINUM ASTM B209	675AT
10 GA. (304) STAINLESS STEEL ASTM A240	715AT

PART NAME 1-1/2" O.D. TUBE FLAT BASE FLANGE W/(3) HOLES				
MATERIAL 10 GA. HRP&O STEEL ASTM A-569				
DATE 1/11/99	WAGNER	R & B WAGNER, INC.		
DRAWN BY R.J.F.				
FINISH MILL	SIZE A	WEIGHT .42 lbs	PART NUMBER 635AT	REV