

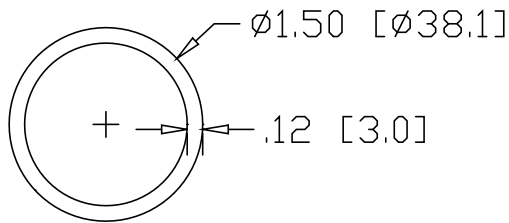

REV  
SH  
6951  
DWG NO

REVISIONS			
REV	DESCRIPTION	DATE	APPROVED

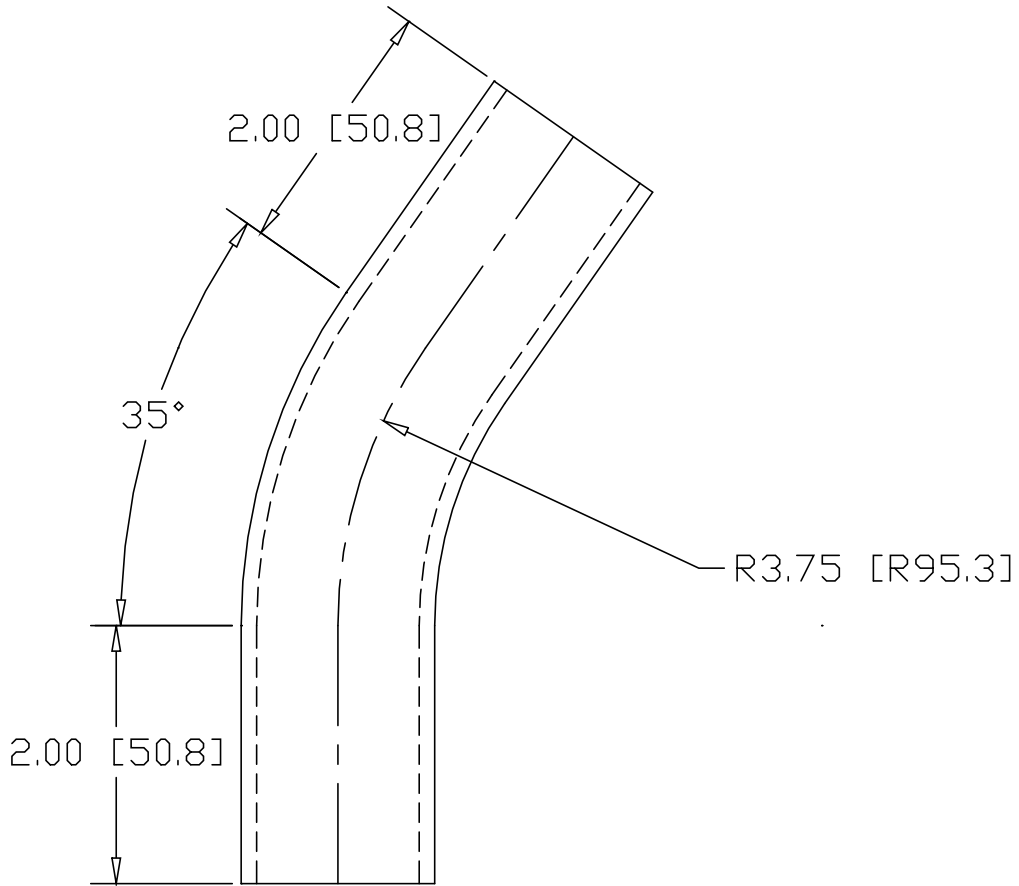

INCHES [MILLIMETERS]

ALTERNATE MATERIAL	PART NUMBER
1.50" Ø.D. X .125W (6061-T1) ALUMINUM TUBE	6964
1.50" Ø.D. X .120W (304) STAINLESS STEEL TUBE	6972

PART NAME 1.50" Ø.D. TUBE 35° ELL X 3.75" CLR W/(2) 2" TANGENTS			
MATERIAL 1.50" Ø.D. X .120W STEEL TUBE			
DATE 9/22/00	 <b>R &amp; B WAGNER, INC.</b>		
DRAWN BY RJF			
FINISH MILL		SIZE A	WEIGHT .93 LBS
			REV