

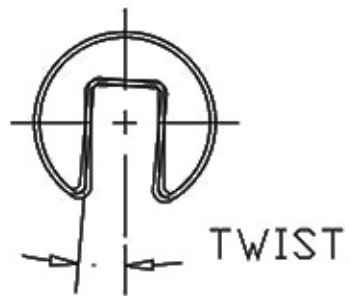

REV C
SH
DWG NO GR3166

REVISIONS			
REV	DESCRIPTION	DATE	APPROVED
A	1.50 WAS 1.45, ADDED R.08 DIM	08/24/05	RJF
B	1.50 MARKED AS "REFERENCE"	10/19/05	RJF
C	REVISED DIMENSIONS AND TOLERANCE	04/01/08	RJF

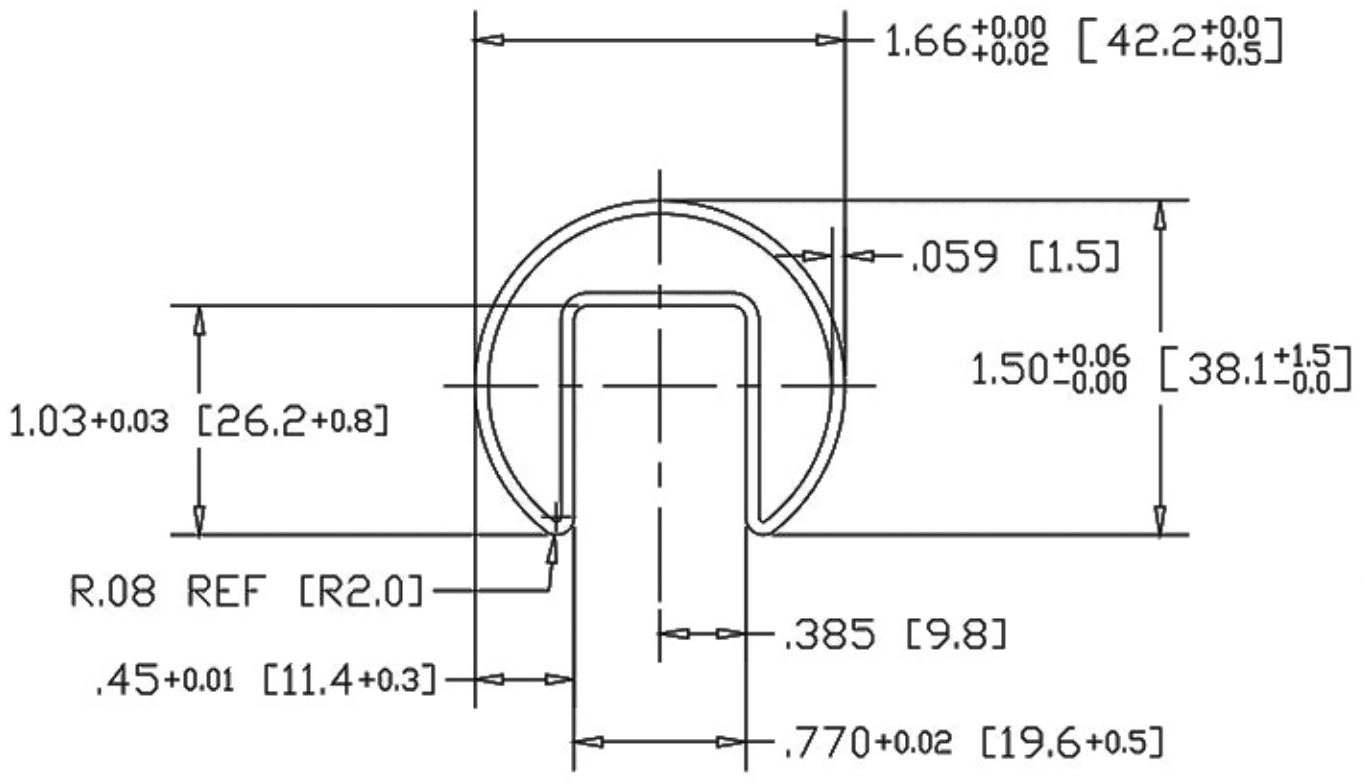

NOTE: MAXIMUM ALLOWABLE TWIST
0.5° PER FOOT WITH MAXIMUM 5.0° PER LENGTH

INCHES [MILLIMETERS]

PART NAME 1.66" OD X .059W STAINLESS STEEL CAPRAIL				
MATERIAL 304 STAINLESS STEEL				
DATE 07/05/05	 THE WAGNER COMPANIES R & B WAGNER, INC. AND J. G. BRAUN CO.			
DRAWN BY RJF		SIZE A	WEIGHT 1.42 LBS	PART NUMBER GR3166
FINISH MILL				REV C