

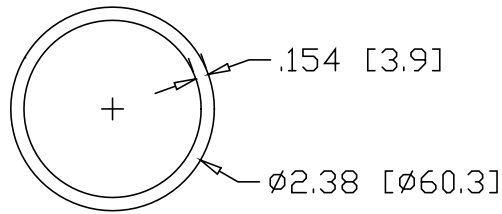

REV
SH
5727
DWG NO

REVISIONS			
REV	DESCRIPTION	DATE	APPROVED

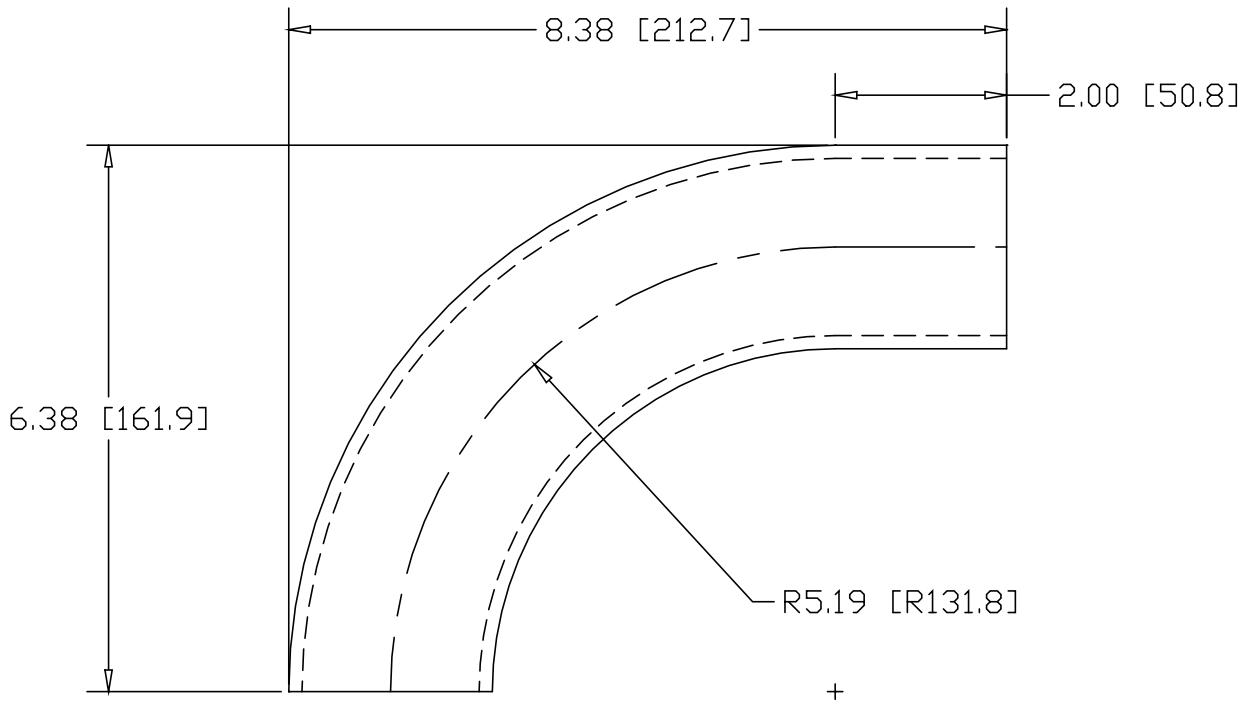

INCHES [MILLIMETERS]

ALTERNATE MATERIAL	PART NUMBER
2" SCH 40 (6063) ALUMINUM PIPE	5741
2" SCH 40 (304) STAINLESS STEEL PIPE	5755

PART NAME 2" PIPE SIZE 90° X 4" I.R. ELL W/(1) 2" TANGENT			
MATERIAL 2" SCH 40 STEEL PIPE			
DATE 4/9/96		R & B WAGNER, INC.	
DRAWN BY RJF		SIZE A	WEIGHT 3.07 LBS
FINISH MILL			REV