

REV
SH
88057
DWG NO

REVISIONS			
REV	DESCRIPTION	DATE	APPROVED

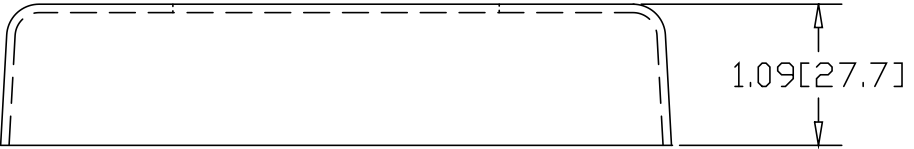
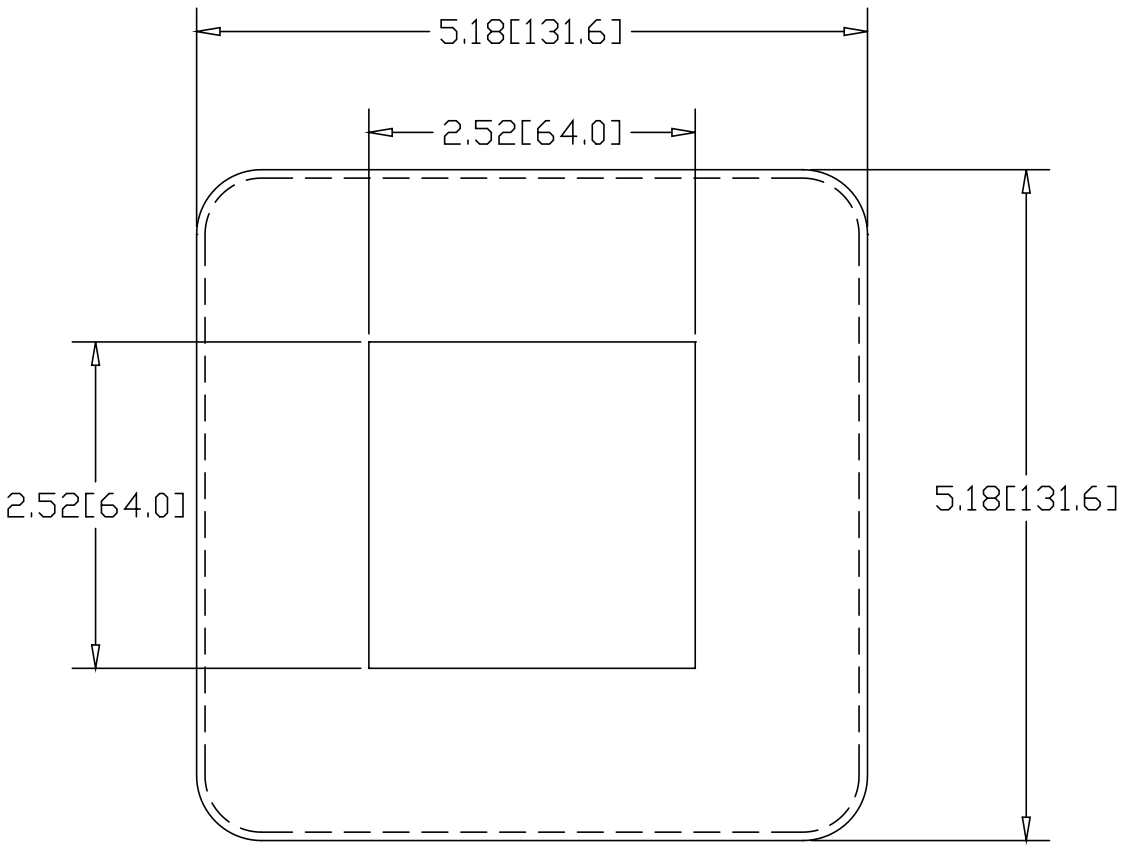

INCHES [MILLIMETERS]

ALTERNATE MATERIAL	PART NUMBER
.063 (3003) ALUMINUM ASTM B-209	88027
16 GA. (304) STAINLESS STEEL ASTM A240	88097

PART NAME				2.50" SQUARE TUBE HFB FLANGE			
MATERIAL				16 GA. CR STEEL ASTM A366			
DATE		6/20/95					
DRAWN BY		RJF					
FINISH		MILL					
SIZE	WEIGHT	PART NUMBER	REV				
A	.57 LBS	88057					