

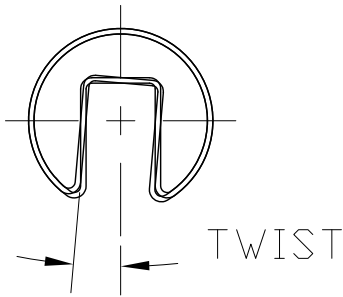

REV D
SH
DWG NO GR3190.4

REVISIONS			
REV	DESCRIPTION	DATE	APPROVED
A	1.77 WAS 1.73, ADDED R.08 DIM	08/24/05	RJF
B	1.77 MARKED AS "REFERENCE"	10/19/05	RJF
C	REVISED DIMENSIONS AND TOLERANCES	04/01/08	RJF
D	REVISED 1.9 OD TOL FOR CASTING FITMENT	03/27/09	PWH

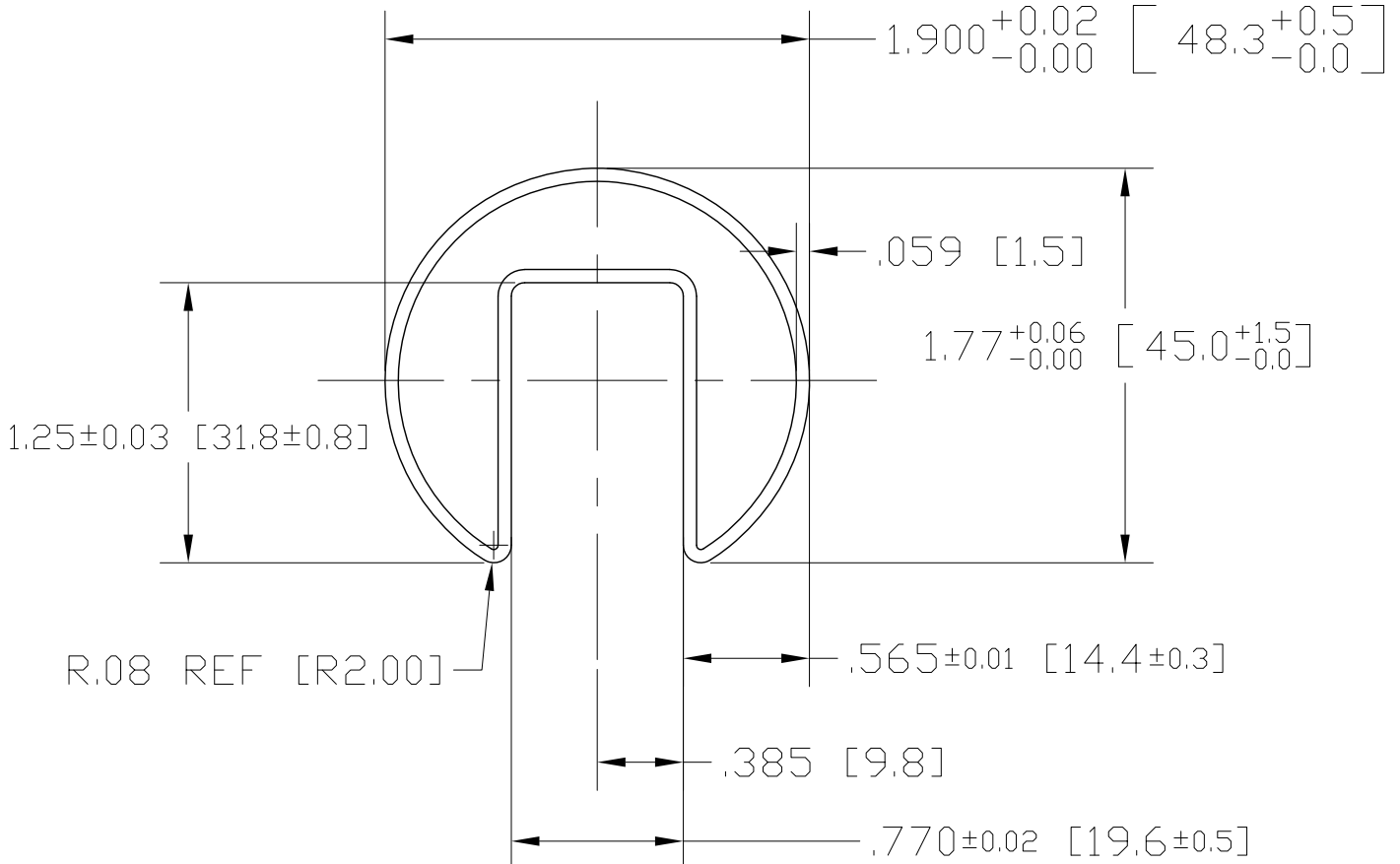

NOTE: MAXIMUM ALLOWABLE TWIST
0.5° PER FOOT WITH MAXIMUM 5.0° PER LENGTH

INCHES [MILLIMETERS]

PART NAME		1.90" OD X .059W STAINLESS STEEL CAPRAIL		
MATERIAL		304 STAINLESS STEEL		
DATE	07/05/05	 THE WAGNER COMPANIES R & B WAGNER, INC. AND J. G. BRAUN CO.		
DRAWN BY	RJF			
FINISH	#4 SATIN CIRCUMFERENCIAL	SIZE	WEIGHT	PART NUMBER
		A	1.67 LBS	GR3190.4
				REV D