

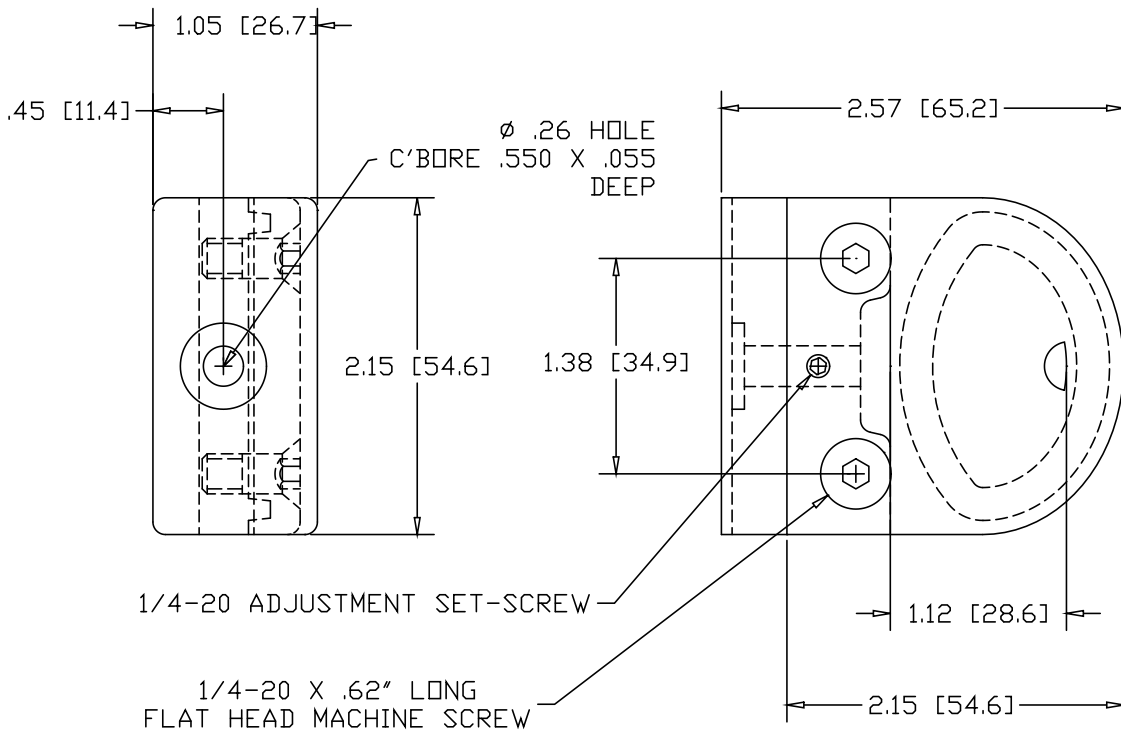

REV
SH
162816-2
DWG NO

REVISIONS			
REV	DESCRIPTION	DATE	APPROVED

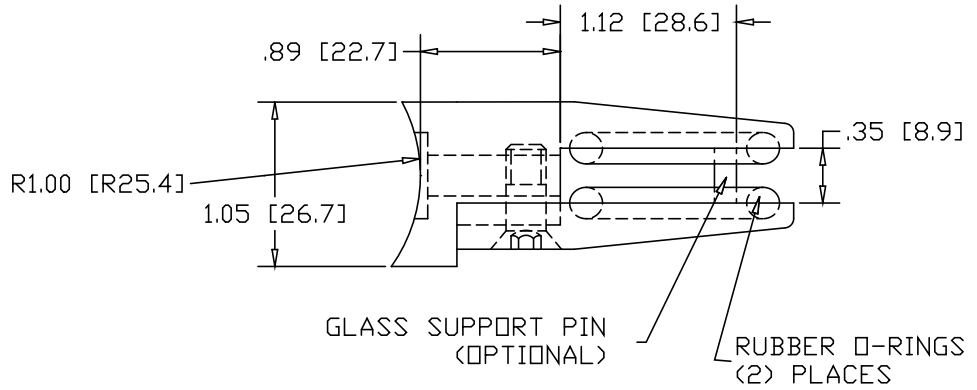

INCHES [MILLIMETERS]

PART NAME				GLASSGRIP ROUND MOUNTING FOR .25" - .38" GLASS					
MATERIAL				TYPE 304 STAINLESS STEEL					
DATE		4/29/05		 THE WAGNER COMPANIES R & B WAGNER, INC. AND J. G. BRAUN CO.		PART NUMBER		162816-2	
DRAWN BY		DGP							
FINISH		MIRROR							
SIZE	WEIGHT			REV					
A	.76 LBS								