

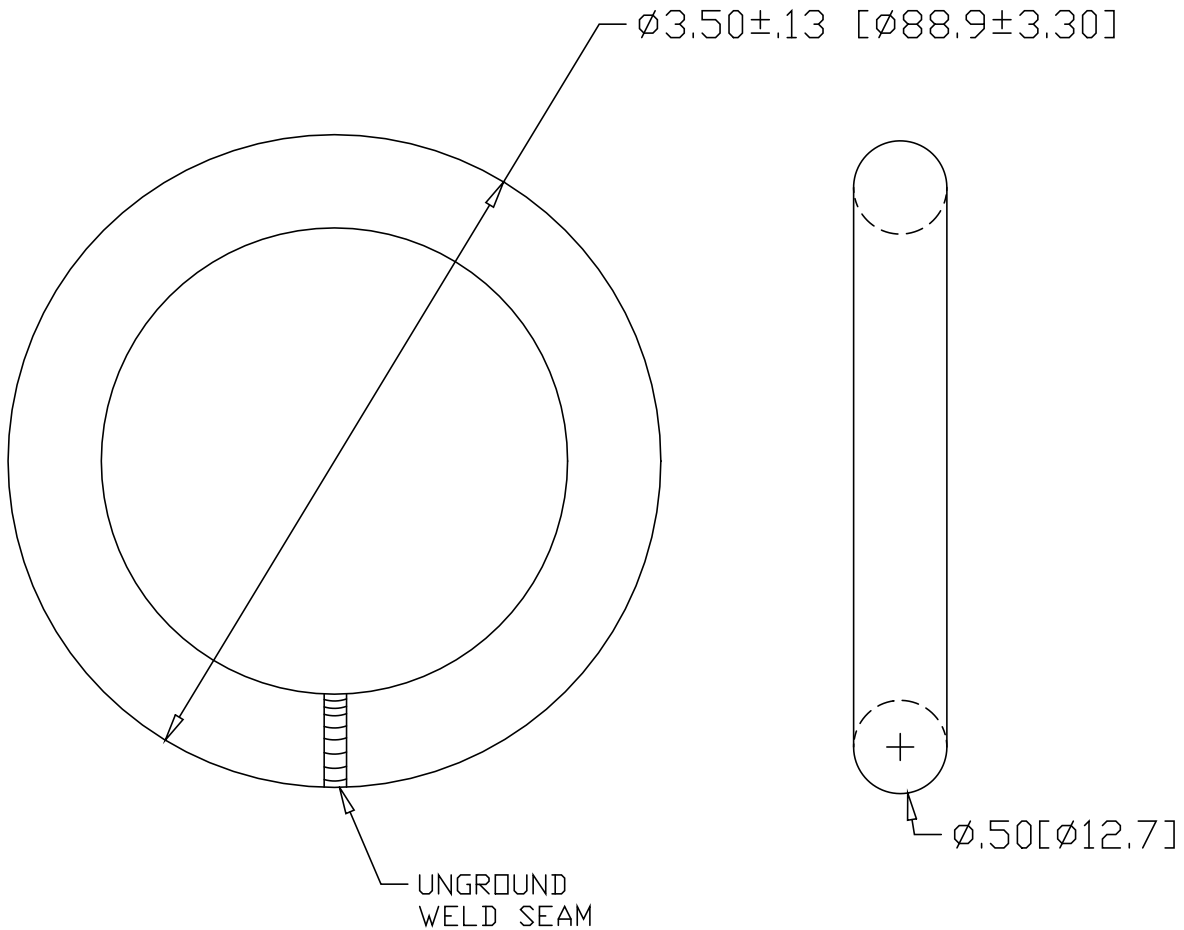

REV  
SH  
4360  
DWG NO

REVISIONS			
REV	DESCRIPTION	DATE	APPROVED



INCHES [MILLIMETERS]

ALTERNATE MATERIAL	PART NUMBER
.50" DIA. (6063-T52) ALUMINUM BAR	4361
.50" DIA. (304) STAINLESS STEEL BAR	4362

PART NAME		.50" X 3.50" OUTSIDE DIAMETER RING					
MATERIAL		.50" DIA. (1018) CR STEEL BAR ASTM A108					
DATE	10/16/98	 <b>THE WAGNER COMPANIES</b> R & B WAGNER, INC. AND J. G. BRAUN CO.					
DRAWN BY	RJF						
FINISH	MILL						
SIZE	A	WEIGHT	.52 LBS	PART NUMBER	4360	REV	